



PERMACON

Architectural Landscape

2025



Decades of *expertise and innovation*

A Big Family

Oldcastle APG has over 8,500 family members throughout our network of facilities across North America. With over 200 locations, we take pride in being the largest producer of architectural building products on the continent. As industry leaders, we drive the trends and set the standards for quality and innovation.

Locally Made

With nine plants across Quebec and Ontario, Permacon specializes in manufacturing high-quality concrete products crafted to meet the evolving needs of today and tomorrow.

Continuous Innovation

Permacon continually refines its processes to deliver products that embody the latest in innovation and excellence.

04 Pavers

06 Boulevard

10 Boulevard Hexagon *New*

12 Boulevard Tactile *New*

22 Agora

24 Paleo-Tec

26 Vertex

28 Ecological Pavers

30 Permeable Interlocking Concrete Pavements (PICP) information

40 Boulevard Verde

44 Boulevard Drain

46 Agora Aqua

48 AquaPave

50 Virage

52 Zen

54 Walls

56 Grande

62 Grande Smooth

64 Keystone

68 Rooftop Terraces

70 SmartCast Reflect

72 Urban

74 Versailles

76 Pedestals for Rooftop Terraces

78 Alternative Landscape

80 Artex Panel System

82 Curbs

84 Street Curbs

Contents





30 Artex Panel System

31 Orion Firepit

Pavers

06 Boulevard

10 Boulevard Hexagon *New*

12 Boulevard Tactile *New*

22 Agora

24 Paleo-Tec

26 Vertex

Boulevard Paver

smooth



textured



Extra-thick architectural pavers, either standard or interlocking,
for a wide range of uses

Expertise with **Architectural Landscaping** Professionals

With over seven decades of experience in a variety of different landscaping projects, Permacon is always pleased to devote the wealth of its expertise and energies to assisting architectural landscaping professionals. Having a thorough understanding of the challenges with which these professionals must grapple, Permacon makes its mission to ensure that every last requirement is met. It is this positioning that has made Permacon a leader in architectural landscaping products.

Precast concrete has long been used to rehabilitate architectural landscaping. In fact, for several decades now, it has been widely recognized by the industry as a durable material. Permacon's extensive technical knowledge has enabled us to push the functions and performance of this product category to new boundaries. In the class of architectural pavers, Permacon offers a complete family of interlocking pavers, called Boulevard TLI (heavy and intense traffic) designed to provide increased durability and structural integrity to the landscaping work (up to 40 or 50 years of service life). This addition complements the existing family of Boulevard pavers that is widely recognized in the industry.





Steeles Avenue, Brampton
BOULEVARD 300

Architectural Pavers

Pavers have been used for decades in architectural landscaping across Canada. Subject to exacting quality standards, and manufactured progressively advanced equipment, architectural pavers have over the years become a construction material of choice when it comes to rehabilitating streets, boulevards, sidewalks and parks. The field of architectural pavers is constantly evolving. With the vast array of colours and shapes available, pavers have seen their ordinary features transform in recent years, with the introduction of some of the most novel surface finishes, including bush-hammered, ground face, and others.

Backed by over seventy years of expertise, Permacon offers a complete line of architectural pavers for all types of applications.

Boulevard Family of Architectural Pavers



Boulevard TLI and TLI Crescendo

New generation of interlocking pavers with peripheral interlocking grooves for maximized stability of the public-use elements. Their large dimensions minimize the number of surface paving joints, while optimizing the interlocking effect. Result: heightened longevity of the structures

Boulevard 300

The most popular of Permacon's architectural pavers. Pavers (100 mm) that come in a variety of sizes up to 600 mm long, as well as a wide selection of surface finishes and colours.

Boulevard 500

Large pavers (500 mm x 500 mm x 100 mm) used in parks and public spaces.

Boulevard Drain

100 mm thick, for performing pervious pavement which aims to better manage water rainfall in architectural areas.

Olympic Stadium, Montreal
BOULEVARD 300

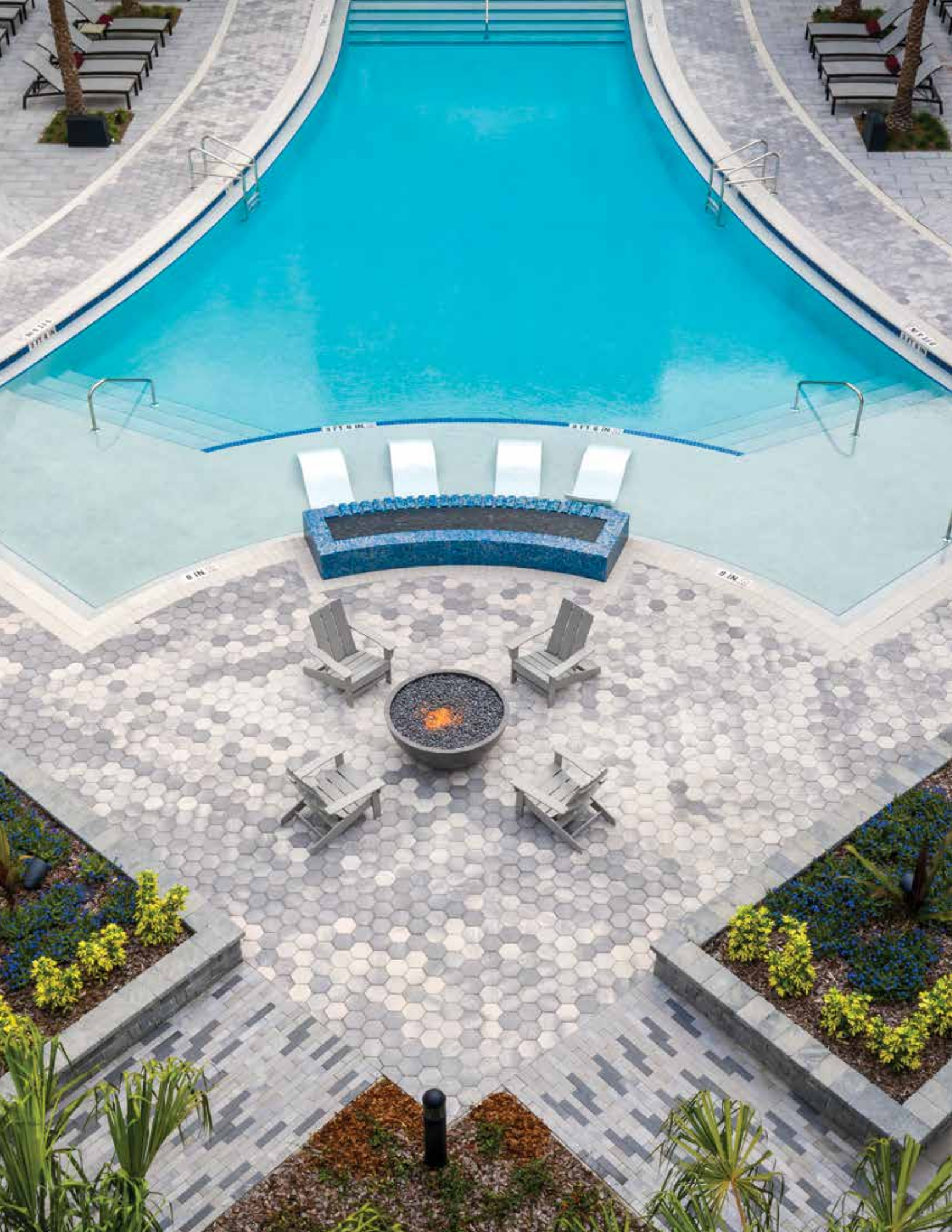

Boulevard Hexagon Paver *New*

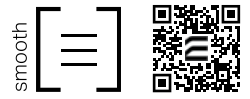

The Boulevard Hexagon paver adds a creative touch to any institutional, commercial or industrial project. Its dimensions match those of Boulevard 300 pavers and allow light commercial traffic. Available in a smooth texture and the same colors as Boulevard and Vertex pavers, Boulevard Hexagon is the ideal accent for any architectural space.

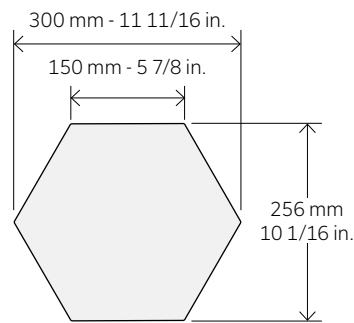

White



Light Grey



Cinder Grey



Beige Grey



Light Charcoal



Charcoal



Beige



Red



ETX Black



Boulevard Tactile Paver *New*



The Boulevard Tactile paver is designed to answer to Canadian standards related to accessibility. Thanks to its truncated domes and colour, the Boulevard Tactile paver acts as an attention indicator to signal elevation changes or hazards in urban areas, such as the end of the sidewalk and beginning of a road.



Cinder Grey





Marina, Saint-Jean-sur-Richelieu
BOULEVARD TLI 100



Saint-Paul Street, Quebec
BOULEVARD TLI 150



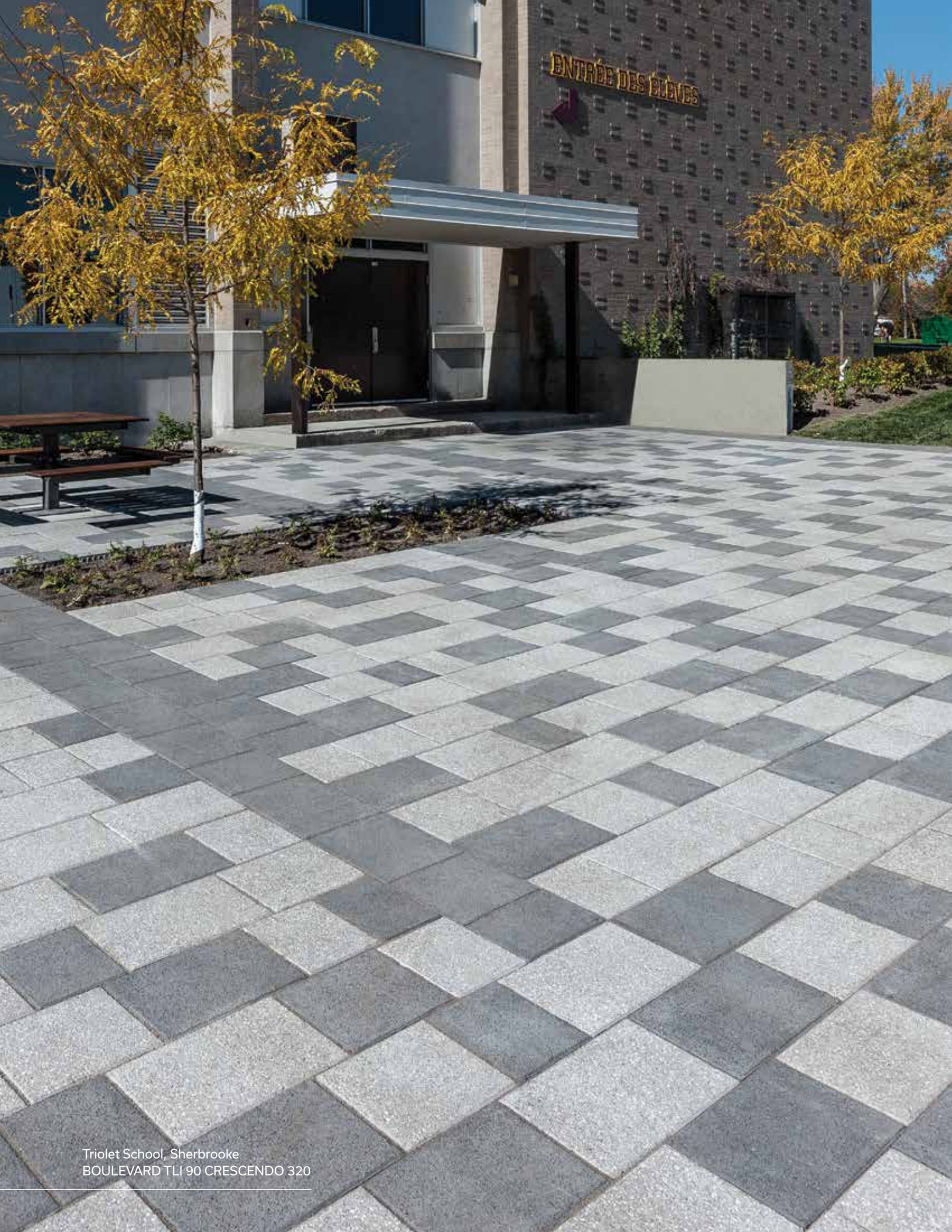

Triolet School, Sherbrooke
BOULEVARD TLI 90 CRESCENDO 320

Boulevard Colours

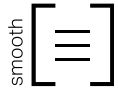

Charcoal



Beige Grey



Cinder Grey



ETX Black

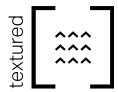

Permacon's Granitech technology is a post-production process that adds a shot-blast finish on Boulevard pavers. This treatment exposes aggregates at the surface of the paver, creating a high-end finish. Granitech is part of Permacon's Textured collection. It provides better surface traction than standard pavers, while maintaining its aesthetic appeal. Therefore, Granitech pavers are an excellent choice for commercial applications.



**Opal White
Granitech**



**Cambrian Brown
Granitech**



**Charcoal
Granitech**



**Beige Grey
Granitech**



**Cinder Grey
Granitech**



**Stanstead Grey
Granitech**



**Cambrian Black
Granitech**





Provides the most stable interlocking pavement system in the industry.



The incorporation of peripheral interlocking grooves into the design of the Boulevard TLI family of pavers maximizes the interlocking effect and ensures the long-term stability of public-use elements.



Agora Paver

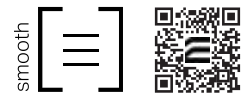

A high-performance paver with a modern and contemporary look

The Agora paver offers a series of attributes ranging from aesthetics to functionality. The smooth finish, a perfect choice for landscape architects looking for a contemporary visual signature. The unique configuration allows a mechanical installation thus ensuring performance and speed

Advantages

- Modern, linear look paired with smooth finish
- Installs mechanically ensuring fast execution
- Affordable product thanks to its of 80 mm thickness
- Offered under two product codes: a product code combining three multi-length units and a product code offering a large rectangle
- Also available in a 100 mm format for road applications

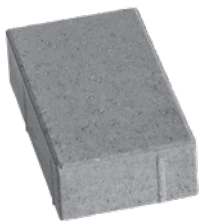

A

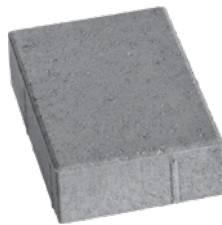

B

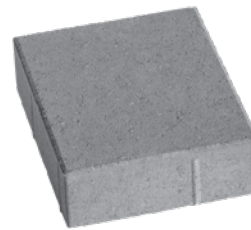

C

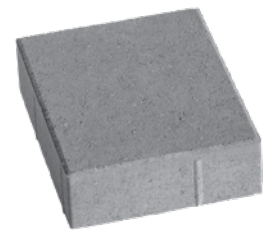

Large Rectangle



Range **Amber Beige**



Range **Shaded Grey**



Range **Scandina Grey**

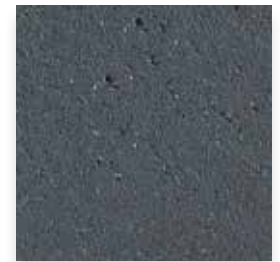

Rockland Black



Paleo[®]-Tec Paver

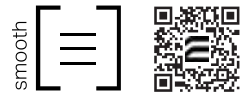

Interlocking pavers for road applications

Interlocking architectural pavers designed to provide long-term structural integrity for roads subjected to high traffic and heavy loads. Their proven performance is made possible by a system of interlocking grooves. Paleo[®]-Tec pavers give roadways an attractive antique look.

Advantages

- Interlocking ensures long-term structural integrity by preventing horizontal and vertical displacement.
- It also redistributes vertical loading on a given unit to several surrounding units, which reduces stress on the upper granular foundation and significantly extends service life.
- Paleo[®]-Tec pavers are extra thick (100 mm), which gives them greater bending capacity and reduces the risk of breaking.



The system of interlocking grooves significantly improves the distribution of vertical loading at the surface and keeps horizontal shifting to a minimum.



Brownstone Red



Range **Light Grey**



Range **Norvick Grey**



Rockland Black



CAFÉ DU PARC CENTRAL

Vertex Paver



Let Permacon's Vertex paver inspire you with their multiple laying patterns. Express your creativity with these 600 mm-long trapezoidal architectural pavers, which perfectly suit the Boulevard 300 paver collection. Vertex pavers can be efficiently installed mechanically to create a unique pattern. Available in all smooth Boulevard colours (by special order), the Vertex paver offers infinite design possibilities.

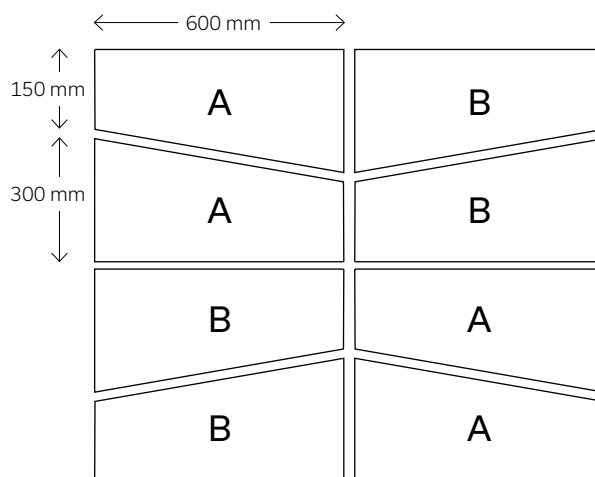
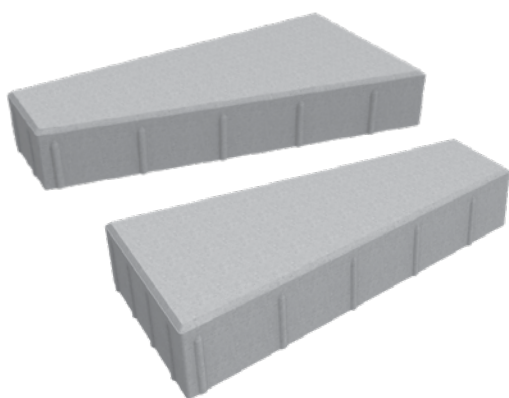

Beige Grey



Cinder Grey



Charcoal



ETX Black

4 installation patterns to create unique designs



Row Pattern



Diagonal Pattern



Insert Pattern

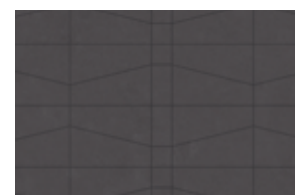

Side-by-side Pattern

Discover more colors and a multitude of Vertex Paver patterns on permacon.ca

Parc du Centenaire

Delson



Fermeture à 23h00

Parc du Centenaire
Aire de concentration et d'observation



Parc du Centenaire
Aire de concentration et d'observation



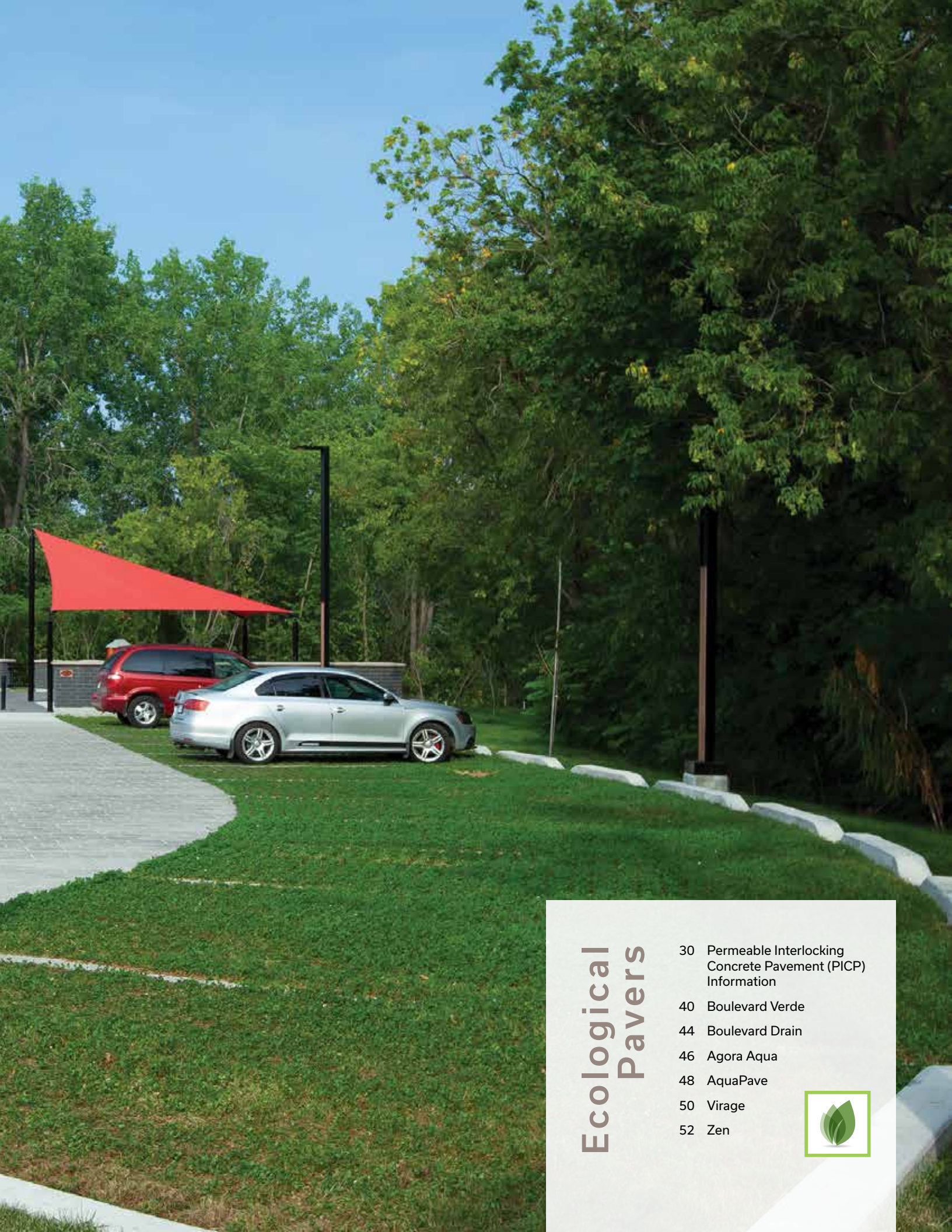

Ecological Pavers

- 30 Permeable Interlocking Concrete Pavement (PICP) Information
- 40 Boulevard Verde
- 44 Boulevard Drain
- 46 Agora Aqua
- 48 AquaPave
- 50 Virage
- 52 Zen





Permeable Interlocking Concrete Pavements (PICP)

Use of PICP on various pedestrian and vehicular applications can add to the aesthetic look of a project, eliminate the need for traditional stormwater conveyance works, improve groundwater quality, and increase usable land space by decreasing or eliminating the need for a retention pond. Permacon experts can work closely with your design team to design and gain approval for the PICP system that best matches the onsite soil conditions, design storms, and local regulatory requirements.

Stormwater Management

PICP Multi-functionality

The cornerstone of sustainability and green infrastructure is multi-functionality. In conventional infrastructure systems, every component has one job to perform. For example, asphalt provides the driving surface, inlets collect the runoff from the pavement, pipes carry the water away, detention ponds store water to reduce the peak flow, and water quality BMPs cleanse the water before it is released into the river. Permeable Interlocking Concrete Pavements (PICP) provide these five functions in one system: 1) The pavers provide a heavy-duty driving surface; 2) The entire paver area captures stormwater; 3) The aggregate filled joints filter out sediment; 4) The open-graded aggregates below the pavers convey water downstream; 5) The voids in the aggregates (approx. 40%) provide storage.

By utilizing the multi-functionality of PICP systems, expensive infrastructure components, including inlets, pipes, water quality devices, and detention ponds, can be eliminated creating additional space for development and lowering overall stormwater management costs. Permeable pavers also last twice as long as conventional pavements and cost less to maintain.

Hydrologic Design of PICP

The hydrologic design will typically govern the final configuration of the system. The most common design methodologies used are event-based hydrograph estimations or continuous simulation modeling. The most common event-based estimation method is the Watershed Hydrology Program (WinTR-20). The most common continuous simulation models are the US EPA Stormwater Management Model (SWMM) and the Hydrologic Engineering Center Hydrologic Modeling System (HEC-HMS).

These methodologies rely on developing a Curve Number (CN), which is an empirical parameter related to the runoff response of a watershed. Because PICP can improve the hydrologic function of a developed area, a reduced CN is used. ASCE 68-18 provides a means for calculating the reduced CN accounting for the storage in the system and infiltration into the soil. The reduced CN is typically slightly greater than or equal to the pre-developed CN.

The Rational Method is not generally used for designing PICP systems, but in some cases regulatory agencies require it. When using the Rational Method, a C-value, which represents the percentage of rainfall that becomes runoff, can be calculated for a PICP system by dividing the total calculated outflow by the total calculated inflow. Typical calculated C-values range between 0.25 to 0.40 depending on the design of the system.

Slope affects the design of the system and once the surface slope exceeds 0.5% flow dams should be considered. The detail below shows how flow dams can be used to increase the efficiency of the system to store and manage stormwater. The flow dams have orifices cut into them and the top of the flow dam is a weir allowing each storage cell created to be modelled as detention basins in series. The lowest storage cell can be connected to an outlet control structure used to attenuate peak flows and meet the allowable release rate of the regulatory agency.

Credit for Pervious Surface

Correctly designed, installed, and maintained, PICP systems have surface infiltration rates higher than that of almost any natural soil, and several times greater than the maximum possible rainfall intensity. This is why a PICP surface should be given complete credit for "100% perviousness," as would a meadow or forest.

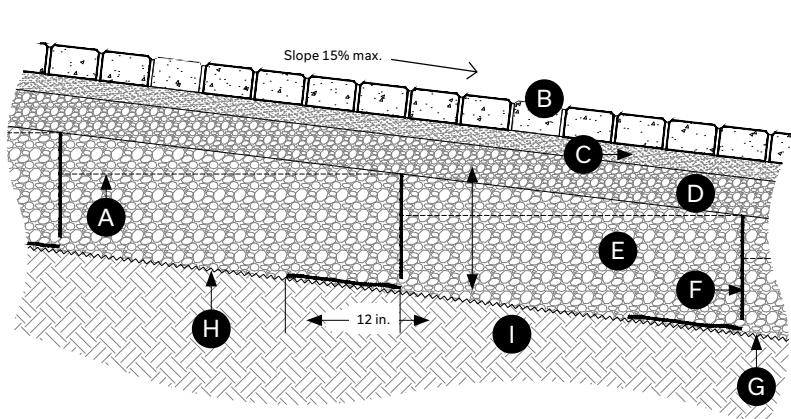

- A High water line (typical)
- B Permeable pavers 3 1/8 in. - 80 mm thick
- C Bedding layer, 2 in. ASTM # 8 stone
- D Base layer, 4 in. ASTM # 57 stone
- E Sub base layer, min. 12 in. ASTM # 2 stone
- F 40 mil HDPE smooth liner baffle
- G 1 in. weep hole, min. of 1 per flow dam. Weep holes can be replaced by an orifice sized by the design engineer. (Include in partial and no infiltration systems)
- H Geotextile filtration fabric on bottom and sides of open graded base if required by the design engineer
- I Subgrade (do not compact)

Preventing Downstream Impacts

Erosion Control

Improperly managed stormwater can result in downstream hydrologic impacts, such as erosion along existing drainage courses, flooding of adjacent low lying areas, and sedimentation/contamination of receiving waters (including ecological areas such as wetlands and estuaries, recreational areas such as lakes and rivers, and/or surface water supplies of drinking water).

These impacts can be minimized, if not effectively avoided, through better site design using PICPs. Studies have shown that "the slower and more controlled outflow (from PICP) closely mimics natural interflow and reduces the risk of flooding and erosion in downstream receiving waters".¹



Reduced Thermal Impacts on Receiving Waters

Under predevelopment conditions, stormwater that infiltrates into the ground stays at a relatively constant temperature; conversely, post development stormwater runoff from impervious areas can be very hot in the summer months and extremely cold in the winter months. These temperature extremes can have a devastating effect on aquatic organisms. Many fish species can be harmed by acute temperature changes of only a few degrees. That is why the Independence & Security Act (2007) requires that predevelopment temperatures be maintained from all Federal development or redevelopment.

With PICP systems, the water is stored below ground, so the thermal temperature impacts are minimal.

Studies conducted at North Carolina State University verified that both warm and cold thermal buffering were provided by shallow infiltration systems like PICP, therein reducing the frequency of harmful temperatures.²

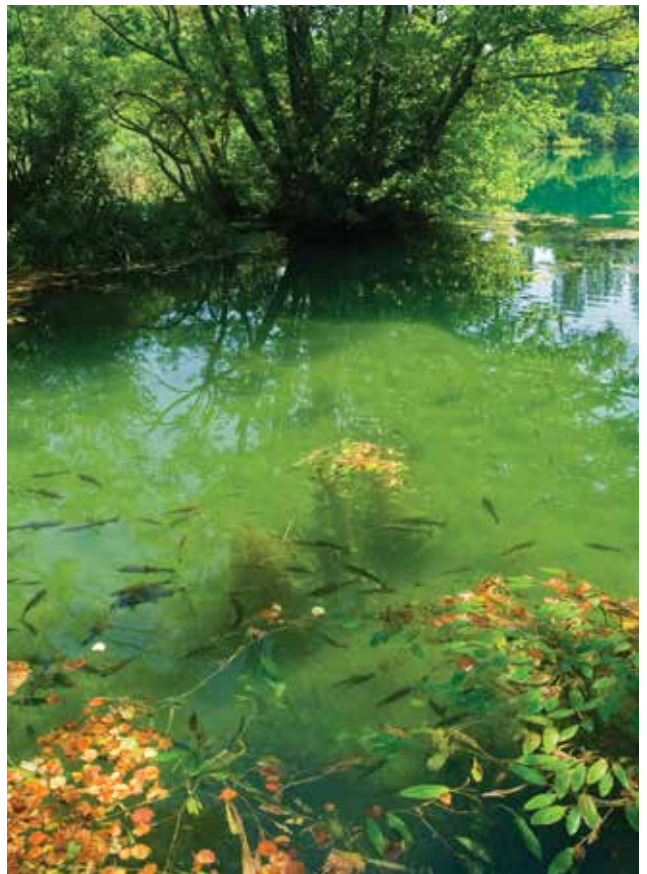

¹ Source: Drake, Jennifer and Tim Van Seters "Evaluation of Permeable Pavements in Cold Climates" Toronto and Region Conservation Authority (TRCA), December 2012.

² Source: Wardynski, B.J., R.J. Winston, W.F. Hunt. 2012. "Thermal Mitigation Potential of Permeable Pavements", LID Research Summit.

Stormwater Quality

PICP reduces pollutant concentrations through several processes including adsorption, microbial action, volatilization and filtration. Contaminants within the subgrade infiltrate will undergo further bacterial and chemical reactions with the native soils prior to reaching the groundwater table or receiving waters.

Filtration is not only effective at removing large particulate and suspended solids, but potentially also metals, Total Phosphorous (TP), and hydrocarbons subject to the degree that each binds (adsorbs) to the filtered particulates. Within the open graded base/subbase, it is expected that volatilization and microbial action in addition to adsorption, is taking place with some pollutants.

Recommended Maintenance

Studies have found a relationship between joint infill material and long term infiltration rates. ASTM No. 8, 89, or 9 stone in properly sized joint openings provide the best performance.

The joints of the PICP system, like any other filter, can become clogged. The FGCU study estimated it would take 7-20 years for a typical system to deteriorate to the point where it is no longer functional (infiltration rate less than 10 inches per hour), with the range being subject to the contaminant loading rate and the size of the jointing material used. Where contaminant loading is concentrated, such as around tree canopies, winter snow storage piles or stormwater run-on areas (water is running onto the PICP surface from adjacent areas), clogging can be accelerated.

The recommended regular maintenance includes semi-annual cleaning (spring and fall) using a mechanical or regenerative air sweeper to remove any surface debris, especially compostables like leaves and winter sand. Annual infiltration testing following ASTM C1781 should also be done on the PICP surface, especially at the previously listed spots. Where the infiltration rate is found to be approaching 10 inches per hour, or where there is any surface ponding noted, restorative maintenance using a vacuum truck should be conducted. Vacuum trucks are capable of extracting the accumulated debris and jointing material from between the pavers. New jointing material is then swept back in, and the system is almost as good as new. Please note that power washing is not recommended as this will only push debris deeper into the joints.

To allow for replacement of pavers that may become damaged, and to ensure an even match with existing, a rule of thumb is to store 2 to 5% of the total project as attic stock. Damaged pavers can be pulled up and the new ones reinstated with a few simple tools.



Regenerative air sweeper for regular maintenance



Vacuum truck for restorative maintenance

Handling Roof Water

In some locations, roof water can be managed by the PICP system if the system is designed to accommodate the additional water volume. When discharging roof water onto the PICP surface, the water is filtered the same as any direct rainfall, but the run-on area may be subject to accelerated clogging. Large roof drains may require flow dissipation to prevent washout of the jointing aggregates. When roof water is diverted into the subbase, filters can be used to pre-treat the roof water and a catch basin can be used to dissipate the energy of the falling water. Surface water can also be collected using catch basin insert filters to pre-treat runoff that enters the catch basin. The illustration below depicts both scenarios.

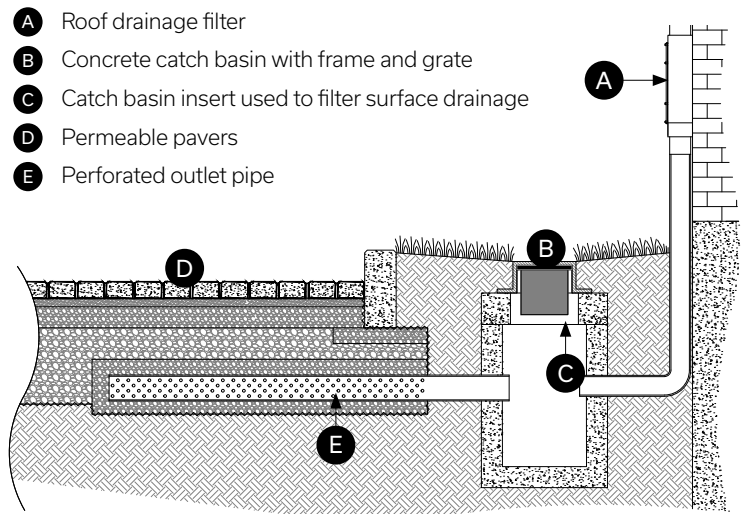

Stormwater Harvesting

Using PICP System as a Storage Reservoir

Water harvesting utilizes a free resource to reduce municipal water supply costs, while complying with regional stormwater management guidelines.

In southern climates, a no infiltration system (complete with liner) can be used as the long term storage reservoir, with the water being used for irrigation, washing, or other non-potable applications. An integrated control system, which include water harvesting information is typically used to operate these harvesting systems. In addition, where the PICP is also serving a stormwater management function, it is recommended that an active control system be used to monitor weather forecast information and to automatically draw down the water volume to accommodate projected precipitation rates.

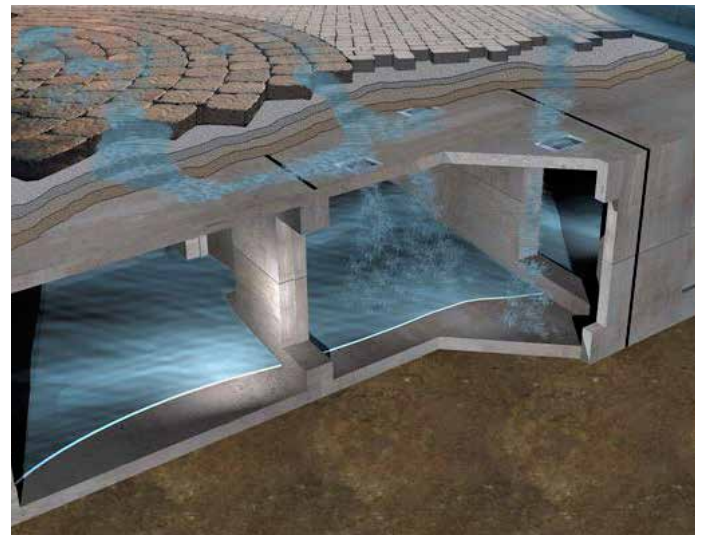

Water harvesting using PICP

- A** PICP Pavement
- B** Curb
- C** Storm capture
- D** Pumped outflow to irrigation system
- E** Open graded base and subbase storage
- F** Permeable liner
- G** Sub-surface drain pipe

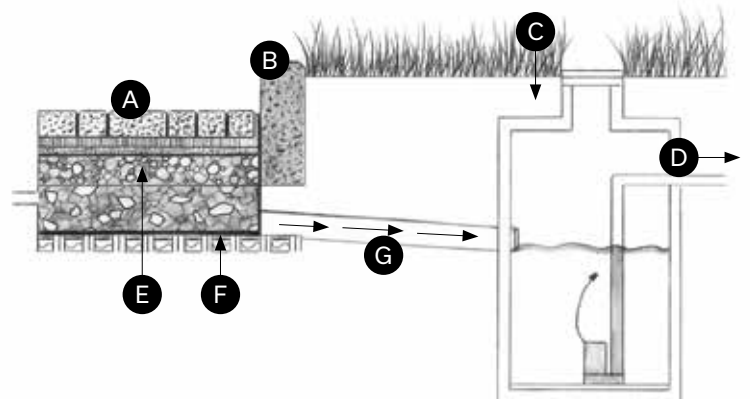

Urban Environment

Reducing Deicing Salt Use

PICP systems perform very well in cold weather conditions. A recent study by the US Geological Survey in 2021 studied temperature profiles over a seven year period from different permeable pavement systems. Data showed that all types of permeable pavement developed favorable conditions to allow surface infiltration during winter rain and melting events with subsurface temperatures remaining above freezing, even when air temperatures were well below freezing. However, PICP was shown to be less susceptible to the effects of freezing air temperatures compared to both pervious concrete (PC) and porous asphalt (PA). The nature of PICP surface voids as well as the thermal mass of pavers may help insulate the aggregate reservoirs from surface temperature fluctuations much better than PC or PA.

A University of Toronto study in 2020 compared deicing operations impact on PICP compared to impervious asphalt surfaces. This research studied the winter safety benefits of permeable pavement and the use of deicing road salts that potentially harming waterways and biological systems. The researchers found that PICP can attenuate and buffer the release of salt to the environment, and that PICP surfaces can be treated with lower application rates of road salts. The study confirmed the general view that PICP eliminates the potential black ice formation from standing water re-freezing.

Rather than use de-icing salts or sand, an alternative is to use the same ASTM #8 or #9 chip as used in the paver joints. Because permeable pavers are made with high quality concrete, snow can be plowed or shoveled without the need for special blades or equipment.¹



Mitigating Urban Heat Island

The “heat island” effect impacts urban areas that have systematically used up existing natural ground cover by replacing them with buildings, parking lots and paved streets. The resulting lack of parkland and trees results in higher overall temperatures in these microclimates. In turn, these temperatures place a higher demand on energy, produce more pollution and greenhouse gas emissions, and clearly create quality of life issues for all those living in such environments.

One strategy to mitigate the heat island effect is to use high reflectance, light-colored paving materials. Solar Reflectance (SR) or albedo, is the percentage of solar energy reflected by a surface. Most existing studies on cool pavements have focused on increasing the solar reflectance which can reduce pavement and even subsurface temperatures. The LEED rating systems require light colored pavers to have an initial SR of ≥ 0.33 for potential credit. Permacon has a large offering of colors that can contribute to heat island mitigation strategies.



¹ Sources: Danz, et. Al, Subsurface Temperature Properties for Three Types of Permeable Pavements in Cold Weather Climates and Implications for Deicer Reduction, 2021, US Geological Survey

Drake, et. Al, De-icing Operations for Permeable Interlocking Concrete Pavements, 2020, University of Toronto

Optimizing Land Use

Increased Value and Safety

In conventional stormwater drainage designs, detention or retention ponds can consume a large portion of the site. These ponds have limited alternative applications (assuming the pond dries out sufficiently for the intended alternative use) and reduce the income generating footprint of the site.

PICP combine the parking and drive lanes with the retention or detention footprint, therein allowing the lands that would otherwise be consumed by the pond to be transformed into continuous use green space, recreational areas, or even reclaimed for increased development.

Examples exist where the use of PICP allowed for the preservation of wooded/ecological areas that would have otherwise been cleared for, or impacted by, the stormwater detention or retention systems.

In other commercial developments or subdivisions, additional building lots were added, with the revenue of the additional building or house exceeding any increased capital cost of the PICP system. In high density developments, more parking spots were available using PICP, and therefore more units were added to the high rise building. One developer in a particularly tight ocean front development referred to the additional parking stalls achieved by PICP as "million dollar lots" as he was able to add a one million dollar condo for each additional parking spot.

With the water detention/retention facility located below ground, we also eliminate public safety concerns associated with the accidental drowning of children and do not provide breeding grounds for insects that transmit diseases like West Nile Virus.

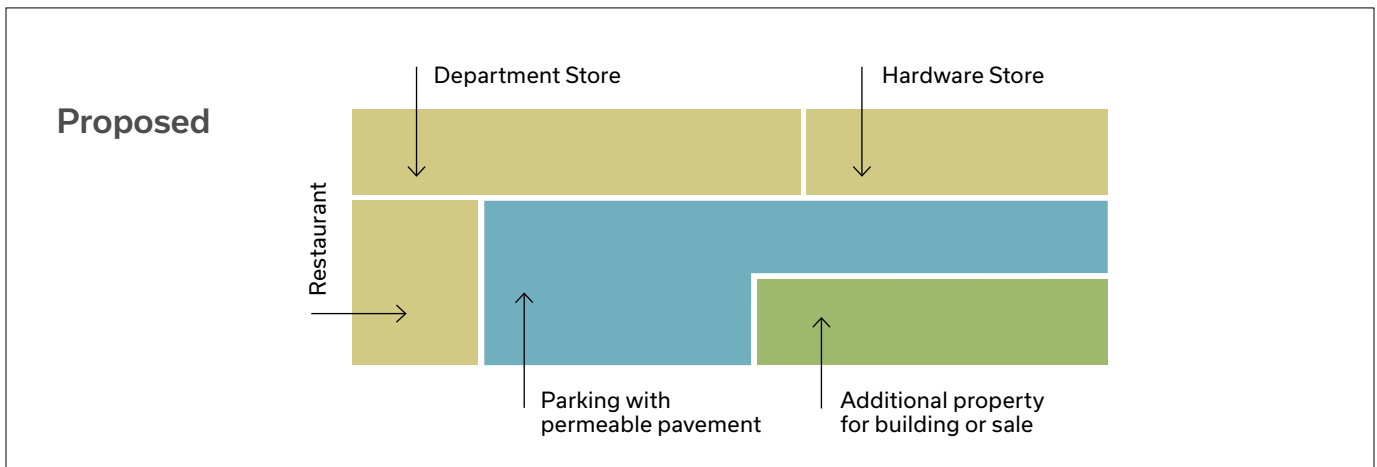
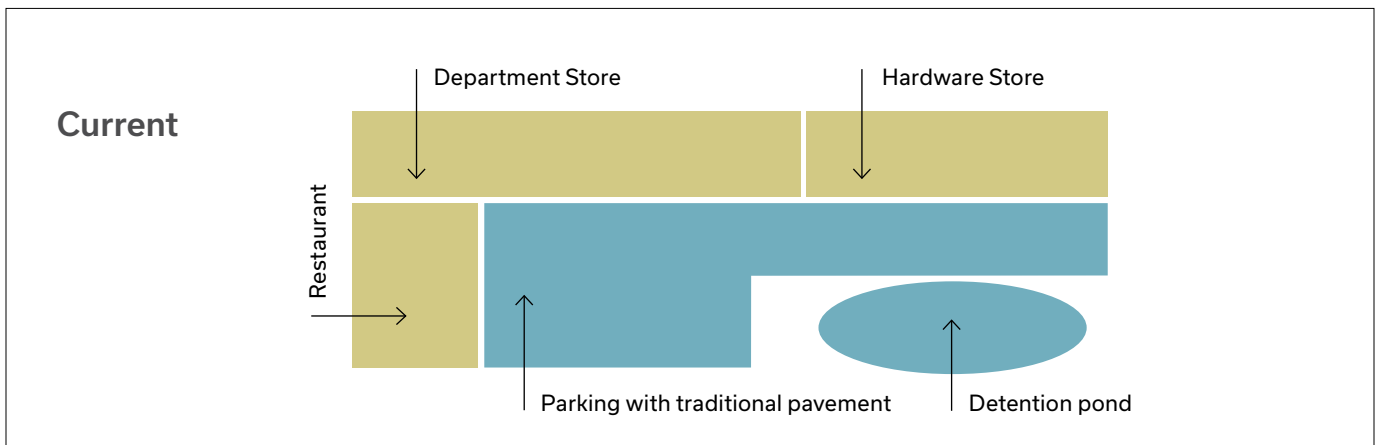

SWM Pave



SWM Pave is an engineered system providing a 5-in-1 stormwater management solution that combines a long-lasting, heavy duty driving surface with these stormwater management functions: collection, water quality, conveyance, and storage. Permacon's collaborative design process assists design professionals (civil engineers, architects, landscape architects) and project owners from concept through completion. With a clear understanding of the project goals, our end-to-end project support from design to installation to maintenance can optimize the project site and can reduce cost, reduce environmental impact, and exceed your site development goals.

SWM Pave was developed to provide a green infrastructure solution and play a role in restoring the vital ecosystem. Our permeable pavers offer robust engineered systems to address both water quality and storage requirements, plus a heavy duty driving surface. These systems can be used in any area where an impervious surface is anticipated.

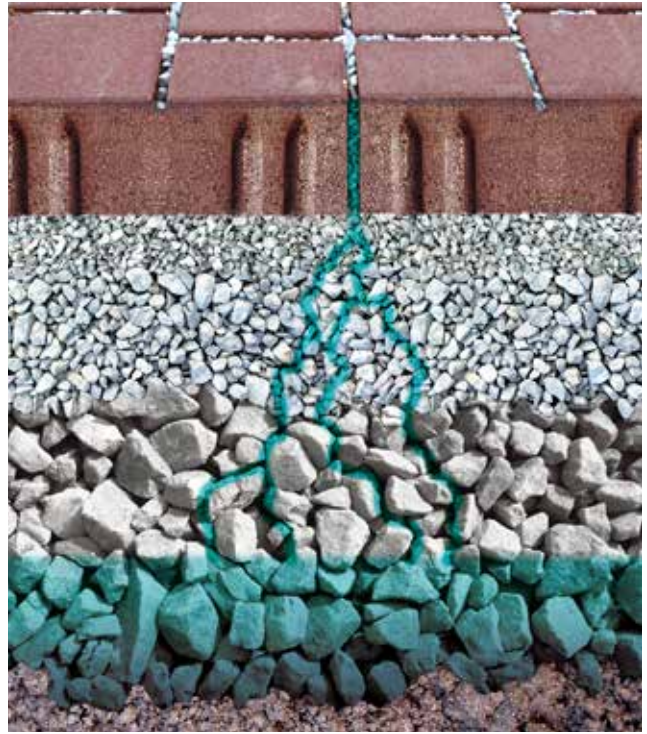

Our Three-Phased Approach

Our comprehensive Three-Phased Approach provides a step-by-step process working closely with the project team on design, construction, and maintenance.

The first phase in the SWM Pave process is design. In this phase we provide regulatory assistance, paver design services, construction details, project specification writing assistance, cost estimating, and life-cycle cost analysis.

The second phase in the SWM Pave process is Construction. Construction details are critical to the project's success and long-term performance. In this phase we provide contractor support, constructability reviews, a network of authorized contractors, installation guides and checklist which all play key roles in the long-term performance of the SWM Pave system.

The third phase is maintenance and is crucial in protecting the integrity and performance of any stormwater management system. Maintenance includes Infiltration testing, inspection checklist, O & M Guides, and maintenance support which defines routine and restorative measures, plus highlights maintenance equipment, procedures for maintaining infiltration, seasonal maintenance schedules and winter maintenance and deicing.

The SWM Pave system offers tremendous value providing both a complete stormwater management system and fully functional driving surface. The SWM Pave team works side-by-side with the project team from concept through continuing maintenance. For more information contact your Permacon representative. Our team is always eager to explain the SWM Pave process and how we can help with construction details, project design, obtaining regulatory approvals, and more.

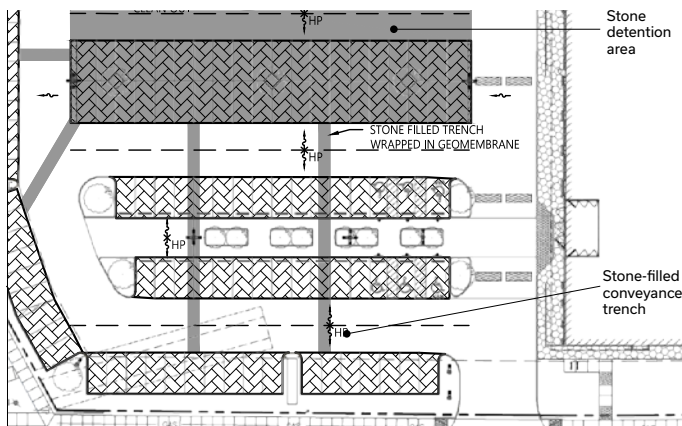

Sample project: Houston, TX

Our Three-Phased Approach includes

1 Design

- Regulatory Assistance
- Paver System Design Services
- Construction Details
- Guide Specifications
- Cost Estimating
- Life-Cycle Cost Analysis

2 Construct

- Contractor Support
- Constructability Reviews
- Network of Authorized Contractors
- Installation Guides
- Installation Checklists

2 Maintain

- Infiltration Testing
- Inspection Checklists
- O & M Guides
- Maintenance Support



Boulevard Verde Paver



smooth



Designed for vehicular vegetated pavements

Boulevard Verde pavers is comprised of one unit measuring 300 mm x 450 mm, with a thickness of 100 mm. It has a smooth surface finish with a small chamfer (3 mm x 3 mm), laid in strips, with vertical joints offset by half a length (225 mm) against adjacent strips. A 59% of total paved area is available for planting. This paver is laid over a standard densified granular foundation for light vehicle traffic, with soil and vegetation well suited to anticipated loading and exposure conditions. It also enables construction of grass paving for light vehicle traffic: public or commercial parking lots, parks, access roads, medians, etc.

Advantages

- Significantly reduces heat island effects
- Reduces stormwater runoff
- Cleans and filters stormwater runoff
- Captures GHGs
- Produces oxygen
- Innovative and aesthetic
- Load-bearing capacity unmatched in the industry
- Incomparable stability and long-term structural integrity
- Can be combined with standard paving to facilitate pedestrian traffic



See list of
Boulevard colours
on page 17

Boulevard Verde is
only available in a
SMOOTH finish



Suitable soil and grass are
needed to ensure long-term
survival

Boulevard Verde Paver

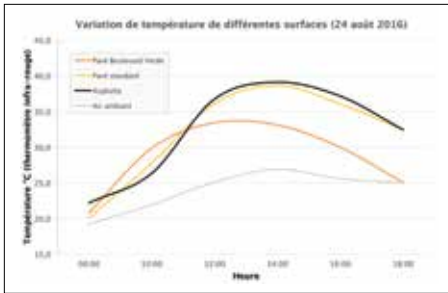

Daily surface temperatures of different pavements.



Boulevard Verde pavers are laid in strips on a conventional densified granular foundation.



Selecting appropriate soil and vegetation is critical to ensure plant survival.



For grass pavements exposed to a lot of vehicle traffic, the recommended fill is structural soil.

A cure for urban heat islands

The loss of forest cover in inhabited areas is responsible for a phenomenon called urban heat islands, characterized by summer temperatures that are higher—often five to ten degrees higher, or even more—than in surrounding rural areas. Urban densification and the rapid development of infrastructure are the two main causes, as soil is replaced by impervious paving materials. During the summer, urban heat islands can create thermal stress with harmful effects on human health, particularly children and the elderly.

Urban cooling with plants

Replanting urban areas and creating new green spaces is, without a doubt, a good way to counter the effects of heat islands. Replacing impervious pavement with grass paving is another way. Both approaches allow better retention of stormwater which, combined with more plants, increases evapotranspiration from paved areas and helps reduce the heat island effect.

Grass paving, an eco-friendly solution

Various options of grass pavement are now on the market. One of the most popular is multi-cavity paving made of prefabricated concrete. First, a conventional densified granular foundation is laid. Hollowed-out *multi-cavity* pavers are placed on it and filled with soil suitable for the conditions the pavement will be exposed to. Plants are then transferred to the pavers. It's critical to select soil and plants that will withstand heat and drought, as well as pedestrian and vehicle traffic.

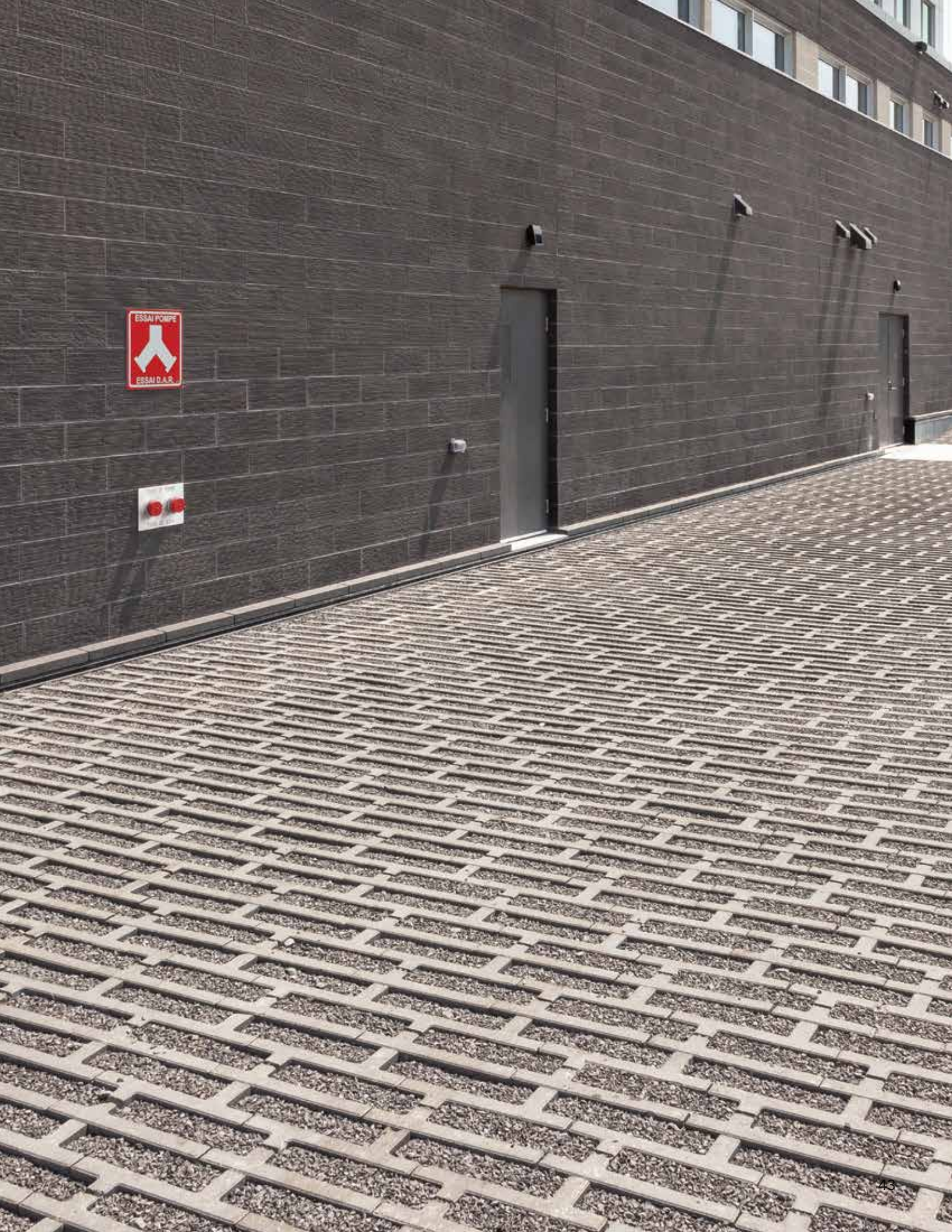

ESSAI POMPE
ESSAI D.A.R.





Boulevard Drain Paver

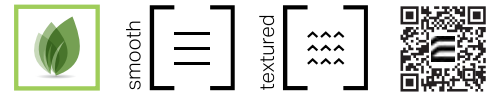

Allows the construction of permeable pavement

In a context of sustainable development, the management of rainwater remains a major challenge for urban planners. The Boulevard Drain paver emerges as the solution to this challenge. Not only does this product provide pavement of great stability, it allows the construction of permeable pavement, an effective solution for all large areas where the instant runoff of surface water can be a problem during heavy rains.

Advantages

- Rapid elimination of surface runoff: allows an initial surface infiltration rate of +/- 17387 mm/hr.
- Significant reduction in the volume of water quickly channelled to the storm system during a rainfall
- Reduction in the volume of water at the treatment plant
- Safer pavement during rainfalls
- Reduction in infrastructure investment costs when starting urban development projects
- Sustainable development (attribution of LEED points)
- Paving system technology, which has already proven its effectiveness in the United States, Canada and Europe
- Strong road surface with the advantages of a flexible pavement adapted to winter conditions

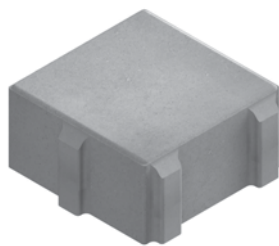

New
Now available in
150 x 300

See list of
Boulevard colours
on page 17

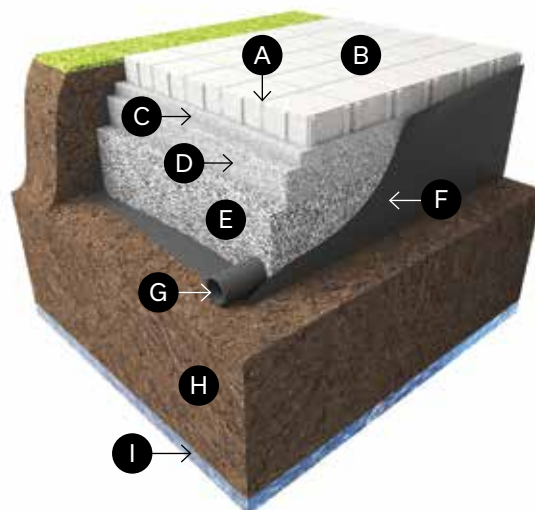

- A Joint filler (road abrasive)
NQ-2560-114-VI crushed stone
- B Boulevard Drain paver
- C Compacted bedding (50 mm max.
crushed stone: 2.5-10 mm)
- D Compacted base (100-150 mm)
crushed stone: 5-28 mm
- E Compacted subbase (min. 300 mm)
crushed stone: 40-80 mm
- F Geotextile
- G Perforated drain
- H Non-reworked existing soil
(thickness: min. 600 mm)
- I Groundwater table (or cliff)



Agora Aqua Paver



smooth



A high-performance paver with a modern and contemporary look

The Agora Aqua paver has a smooth, linear surface offering a contemporary look. Thanks to its mechanical installation, this paver is a quick solution for large urban environments. An eco-friendly paver that allows for the responsible management of runoff water.

Advantages

- Modern, linear look paired with smooth finish
- Installs mechanically ensuring fast execution
- Affordable product thanks to its 100 mm thickness
- Offered under two product codes: a product code combining three multi-length units and a product code offering a large rectangle
- Allows an initial surface infiltration rate of +/- 13300 mm/hr.

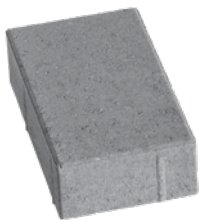

A



B

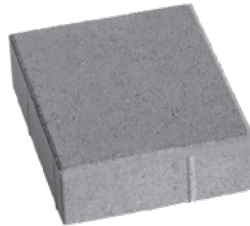

C

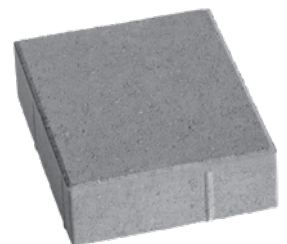

Large Rectangle



Range **Amber Beige**



Range **Shaded Grey**



Range **Scandina Grey**



Rockland Black



AquaPave Paver

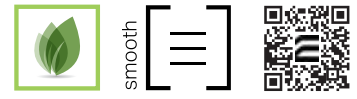

Complete permeable paving system designed for the management of urban runoff

Urban planners currently face an increasingly critical challenge of urban runoff management in a context of rapidly increasing volumes of stormwater directed to sewer systems that are more and more overloaded. The situation is becoming progressively worse with the spread of impermeable urban surfaces. A cost-efficient and eco-friendly solution would be to increase the area of permeable paved surfaces in urban zones.

The AquaPave paver is the main component in a comprehensive permeable paving system for managing urban runoff and eliminating air pollutants from rainwater. The use of AquaPave pavers is an obvious and effective solution for reducing impermeable urban surfaces.

Advantages

- The AquaPave system reduces, or in some cases eliminates, the need to build complex and costly detention tanks or underground drainage systems
- It also reduces the volume of water in the existing underground drainage system by temporarily detaining rainwater for later release, and thereby meets the criteria of the LEED environmental program regarding stormwater management
- It allows for projects for complete or partial water infiltration into the ground, or even for no infiltration if the water is recovered
- Allows an initial surface infiltration rate of +/- 3018 mm/hr.



Grey

Other colours available upon request

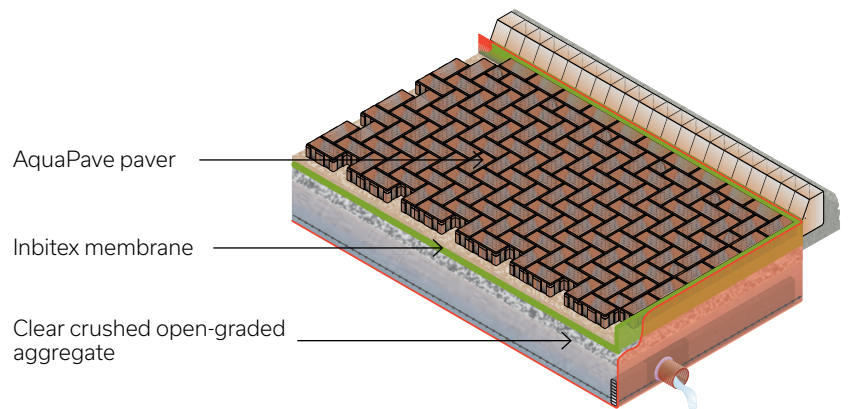



Virage Paver

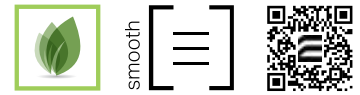

The unique Virage pavers, inspired by European innovations, transform any exterior design into a true architectural masterpiece. With only a single paver, seven laying patterns are possible, each more creative than the other. Whether they are filled with clean aggregates to improve water infiltration into the soil or vegetated to reduce urban heat islands and capture harmful CO₂ from the air, Virage pavers allow you to create an environment-friendly space that reflects your image.

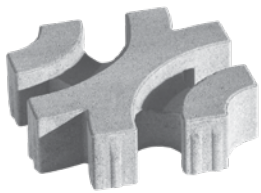

Range **Scandina Grey**

8 installation patterns to create unique designs



Beaded Pattern



Circle Pattern



Link Pattern



Mosaic Pattern



Random Pattern



Wave Pattern



Flower Pattern



Clover Pattern



For more laying patterns, see our Installation Guide.



Zen Paver

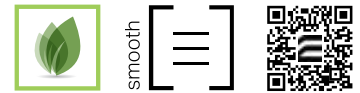

Zen pavers are an eco-friendly and aesthetic solution for parking spaces. These low carbon footprint pavers, filled with clean aggregates or vegetation, significantly reduce erosion, ensure natural stormwater infiltration and provide thermal and water regulation.

Avantages

- With built-in 40 mm spacers on one side only, Zen pavers give you the choice of spacing, depending on the installation: back-to-back, face-to-back or face-to-face
- With the same format as Melville Small Rectangle pavers, Zen pavers are a permeable alternative to the popular Melville small rectangle pavers

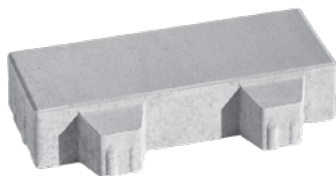

Range **Amber Beige**



Range **Scandina Grey**

Linear Patterns

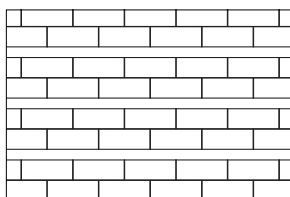

Face to face

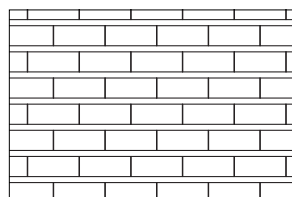

Face to back

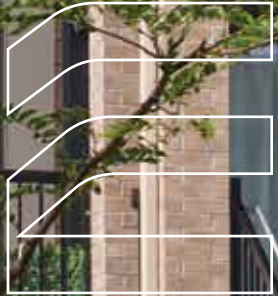



Walls

- 56 Grande
- 62 Grande Smooth
- 64 Keystone



Grande Wall



Large concrete blocks for the construction of retaining walls

The Grande wall system is designed for building retaining walls that are highly stable, durable and aesthetic. The system replaces reinforced concrete walls cast in place. The solid concrete units of the Grande system permit the construction of gravity walls. In addition, they may be used with geogrid-type soil reinforcement for purposes of economy or for the construction of extra-high retaining structures permit the design and construction of gravity walls and geogrid reinforced type walls in excess of 9 m (30 ft).



Aesthetics enhanced by contrasting angles and textures

Grande Wall



The Grande wall system allows for the construction of highly stable retaining walls in commercial and industrial applications.

Description

The Grande wall system comprised of three distinct large-format units. The unique connection system of grooves and ridges on each Grande block provides outstanding performance and greater load resistance compared to conventional retaining walls. It also allows for the construction of walls with various possible setbacks for greater stability.

The visible surface of the wall has a split finish. Units are available in natural grey colour.

This type of wall is typically used for commercial and industrial applications. It is ideal for constructing parking areas, loading bays, driveways for trucks or to ensure the stability of a slope. It can also be used as a separator wall (double-faced) or even as a noise-reduction screen.

Variable set backs

The system of grooves and ridges on Grande blocks allows for the construction of walls with various possible setbacks (0 degrees, 9 degrees and 17 degrees) for greater stability.

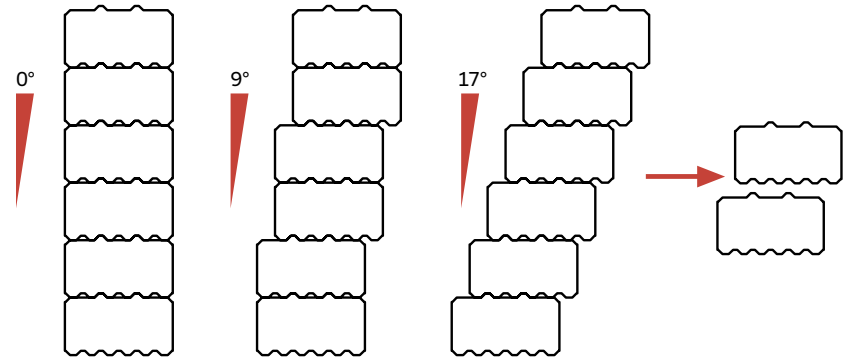

The efficient, self-locking system of Grande blocks also permits the use of geogrids for building extra-high walls, thereby reducing product costs.

Straight or curved walls

Grande walls can be built straight or curved using bevelled Wedge units designed for the purpose. A curved gravity wall can be erected to a height of 1.0 m (3.3 ft) and a curved wall with geogrid reinforcement can reach a height of 9.0 m (30.0 ft).

The system allows for internal and external 90° corners using corner units.

Special angle corners available upon request.



Grande Wedge Wall



Grand Wedge Capping Unit



Grande Wall Corner Unit

Grande Wall

Construction Advantages

- Grande blocks are manufactured to high quality standards to withstand the harsh northern climate and de-icing salts
- The Grande wall system is particularly economical compared to reinforced concrete retaining walls poured on site
- Does not require deep foundations to protect against freezing
- Does not require steel reinforcement or formwork
- Does not require anchors or mortar
- Installation is fast and easy because Grande units are put in place with the lifting device (clamp) supplied and are moved around with a backhoe, thereby reducing labour and other costs
- The large format of the blocks enables guardrails to be directly attached
- Coping or grande 175 units can be used for rapid construction of solid steps
- Grande units are highly impact-resistant
- The Grande system has been used for over 35 years and thousands of walls have been constructed in Quebec and Ontario



Grande walls are strong, durable and aesthetic



Grande walls allow for curved designs

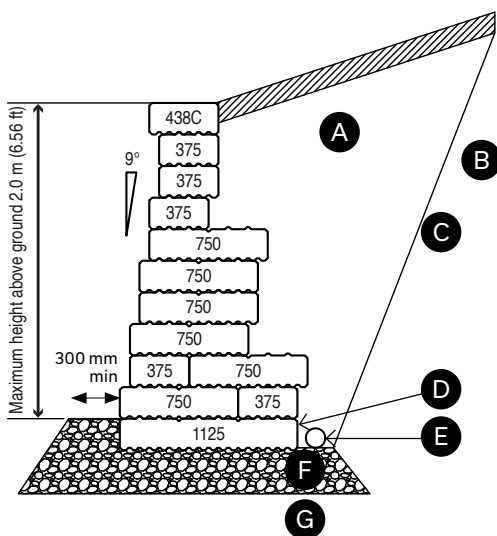

- A** Granular drainage material (sand and gravel) compacted to 95% covered with a semi-permeable membrane to install Permacon products. Maximum passing: 8% in a 200-mesh sieve
- B** Existing unprocessed soil (minimum 30° internal angle of friction)
- C** Excavation angle as per local safety regulations
- D** Buried section (200 mm minimum)
- E** Perforated drain, 100 mm diameter, connected to municipal services
- F** Granular base, minimum thickness 300 mm, composed of 0-20 mm crushed stone compacted to 95% M.P.
- G** Existing unprocessed soil or structural backfill with a minimum load-bearing capacity of 150 kPa

Grande Wall

Typical Grande wall design charts

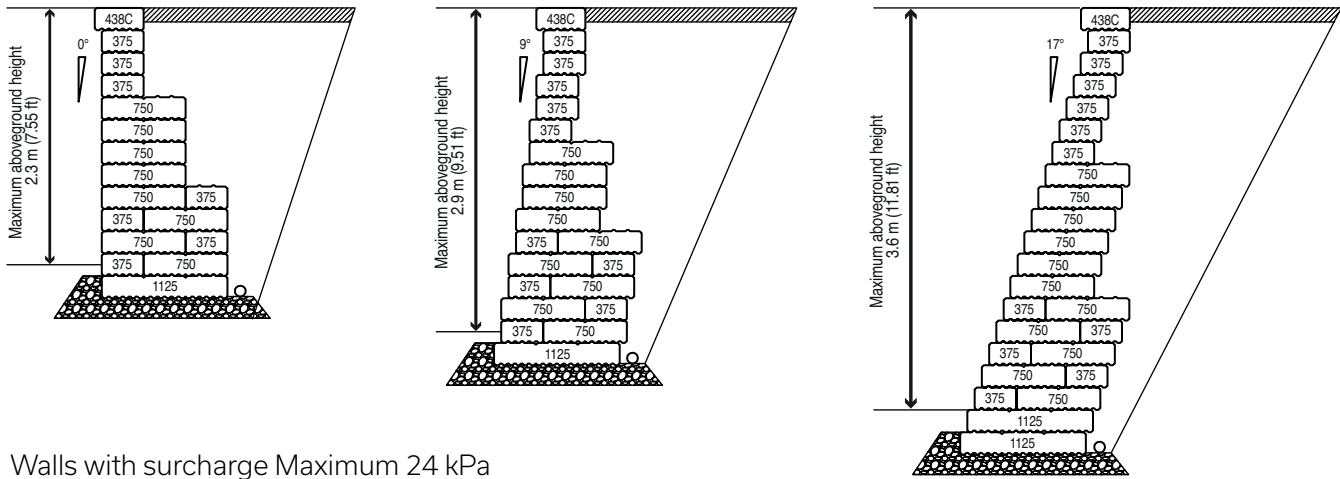

Walls with surcharge Maximum 24 kPa

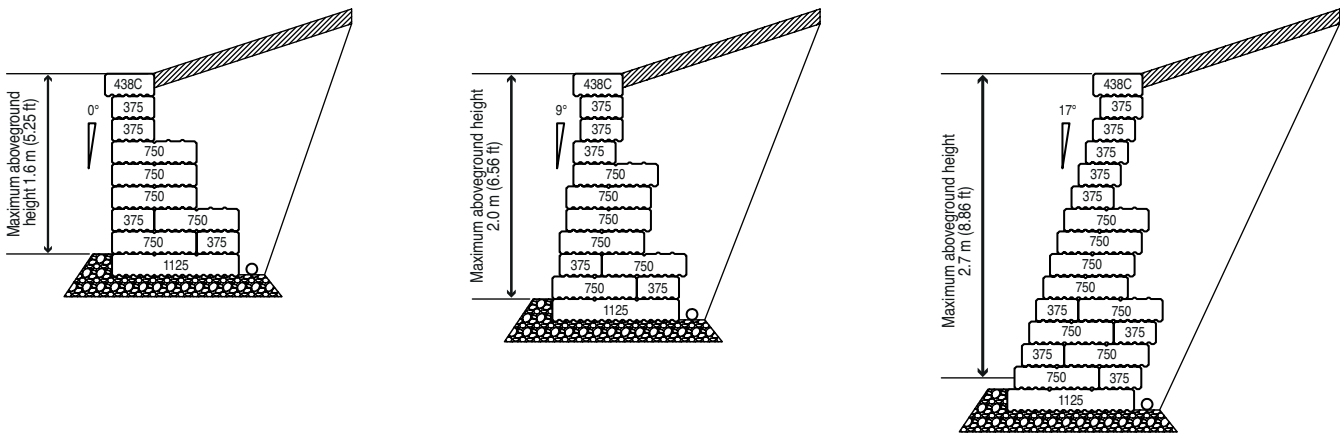

Walls with surcharge at varying angles (maximum gradient of slope—1 vertical: 3 horizontal)

Limitations of use

The design charts reflect the following assumptions:

The backfill material at the rear of the wall and the existing soil to be retained must have an internal angle of friction of at least 30° . The bearing capacity of the soil under the granular base must be at least 150 kPa (3150 lb/ft²).

These charts have been developed using 1125 mm units as the depth of the base, limiting the maximum aboveground height to 3.6 m (11.81 ft). However, the wall height can be increased by adding additional units to build broader bases. Grande walls can be designed and built in excess of 9 m (30 ft).

Grande Wall



Using geogrid lets you increase wall height and minimize construction costs.

Cross-sections of walls illustrated in the design chart on the previous page are available for the majority of popular uses. For more complex applications, please consult our engineering department.



Large-scale walls may be straight or curved



Fence incorporated directly above wall

The Grande wall varies from project to project depending on individual specific parameters (gravity or reinforced wall, slope of wall, type of soil, live load, height of wall, etc.). Please consult your Permacon sales representative to provide you with specific designs and cross-sections.



Since the design of a Grande Smooth Wall varies from one project to another, depending on the specifications of each, Permacon is able to provide a custom cross-section. For more information, please contact your Permacon representative or send an inquiry directly to our website.

Grande Smooth Wall

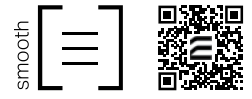

Permacon's new Grande Smooth wall is ideal for small to large-scale retaining walls

The Smooth Grande Wall is available in a wide range of sizes. Equipped with a tongue and groove interlocking system, it can be installed by gravity or on a reinforced geogrid, depending on the context.



375 Standard
200 x 375 x 1000 mm
7 7/8 x 14 3/4 x 39 3/8 in.



750 Standard
200 x 750 x 1000 mm
7 7/8 x 29 1/2 x 39 3/8 in.



1125 Standard
200 x 1125 x 1000 mm
7 7/8 x 44 5/16 x 39 3/8 in.



Corner unit
200 x 500 x 1000 mm
7 7/8 x 19 11/16 x 39 3/8 in.



Capping 438
200 x 438 x 1000 mm
7 7/8 x 17 1/4 x 39 3/8 in.



Step 175
175 x 438 x 1000 mm
6 7/8 x 17 1/4 x 39 3/8 in.

Grande Smooth Wall 3 m (9.8 ft.)
15 rows straight gravity

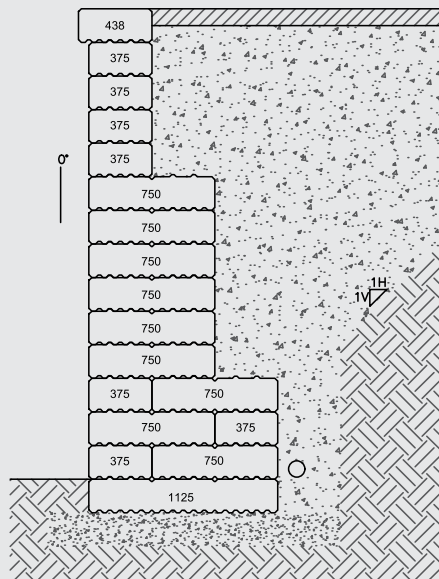

Grande Smooth Wall 3 m (9.8 ft.)
15 rows 9° reinforced slope

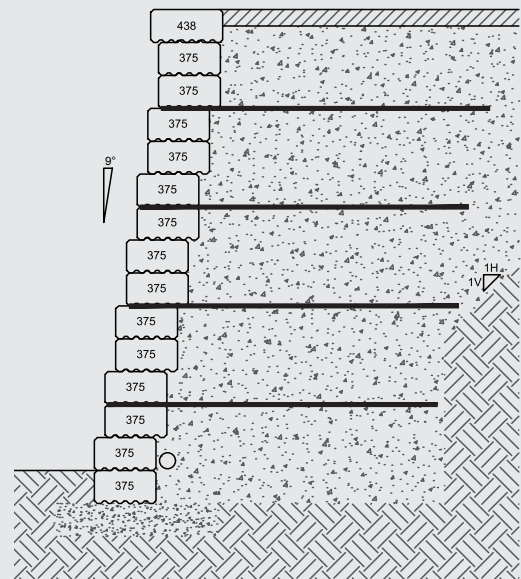



Keystone Wall



Concrete block and geogrid system designed for stronger reinforced retaining walls

The Keystone wall system is designed specifically for the construction of large-scale retaining walls. Both cost-effective and aesthetic, it is an economical replacement for reinforced concrete walls. Combined with geogrid-type reinforcement, Keystone walls can be erected to a height of 9.0 m (30.0 ft). They are also very easy to build.

Description

The system is comprised of concrete blocks mechanically held together by high-strength, fibreglass anchor rods and geogrid-type soil reinforcement to ensure great structural stability. The visible surface of the wall has a split finish with a straight face. The system is used for straight walls and is available in Smoke Grey.

This type of wall is intended for commercial, industrial and institutional applications around the margins of viaducts, bridges and culverts. It has been one of the retaining walls approved by the Ministry of Transport of Quebec (MTQ) since 2001. It is perfectly suited for road landscaping, truck access routes, parking lots, loading bays and for retaining all kinds of slopes.



Compact Unit Straight Face



Corner Unit

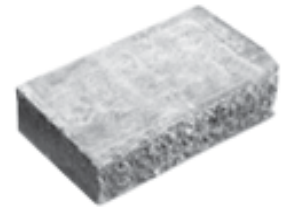

Straight Capping



Smoke Grey

Since the design of a Keystone wall is unique for each project, engineer and design review will be offered for custom cross-sections.

Keystone Wall

Advantages

The Keystone wall system is particularly cost-effective compared with reinforced retaining walls cast in place.

- Permits fast, manual construction of straight or curved walls without special handling equipment
- Requires no formwork and can even be erected in cold weather
- Strict monitoring of product quality ensures compliance with rigorous requirements of government agencies involved. The Keystone wall system meets the highest quality standards to enable the product to withstand the harsh northern climate.
- The Keystone system has been used across America for over 25 years, and hundreds of walls have been constructed in Quebec and Ontario with exemplary performance

Large-scale, economical and aesthetic walls



Keystone Wall

Cross-section

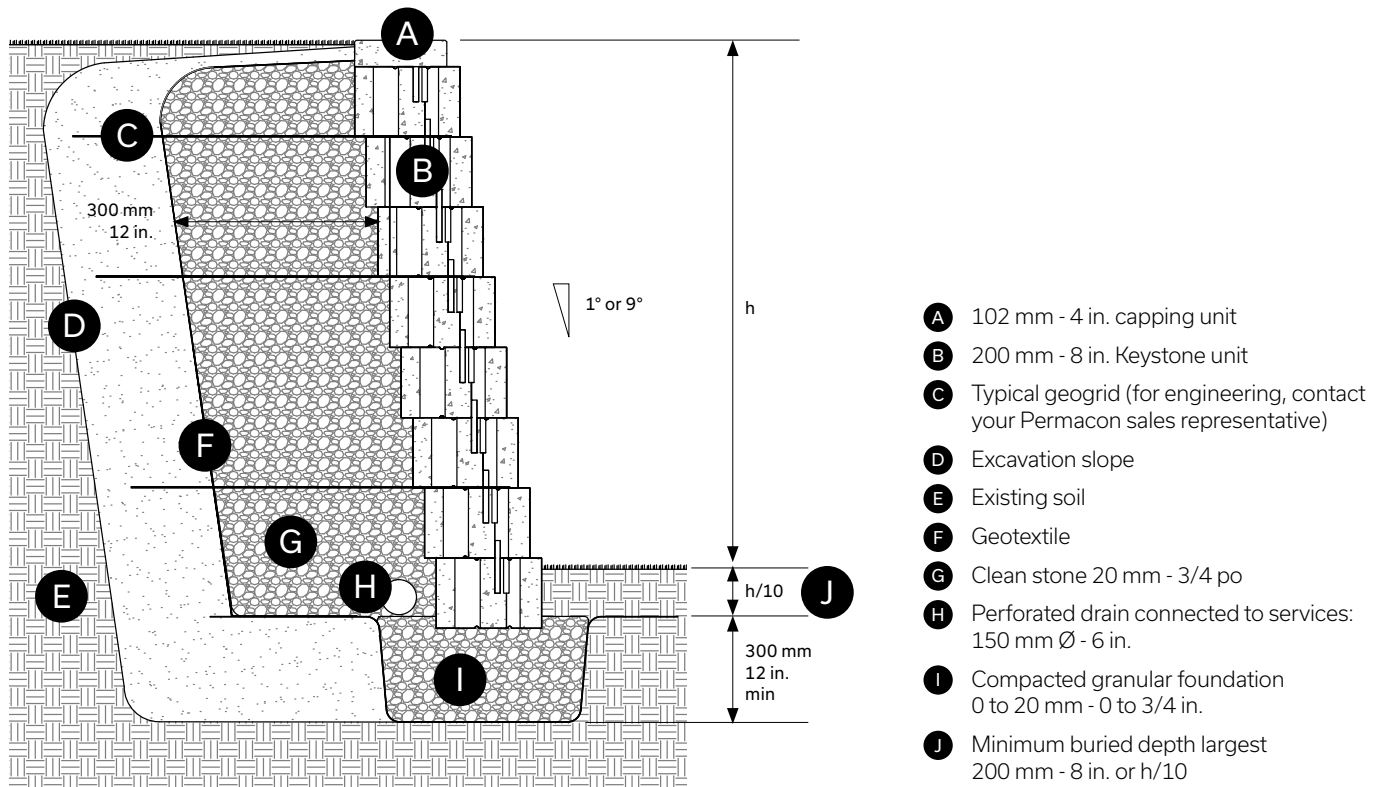

Limitation of use

- Maximum height of gravity wall limited to 0.7 m (2.33 ft.)
- Reinforced walls may reach heights up to 9.0 m (30 ft.)



Use of geogrid reinforcement



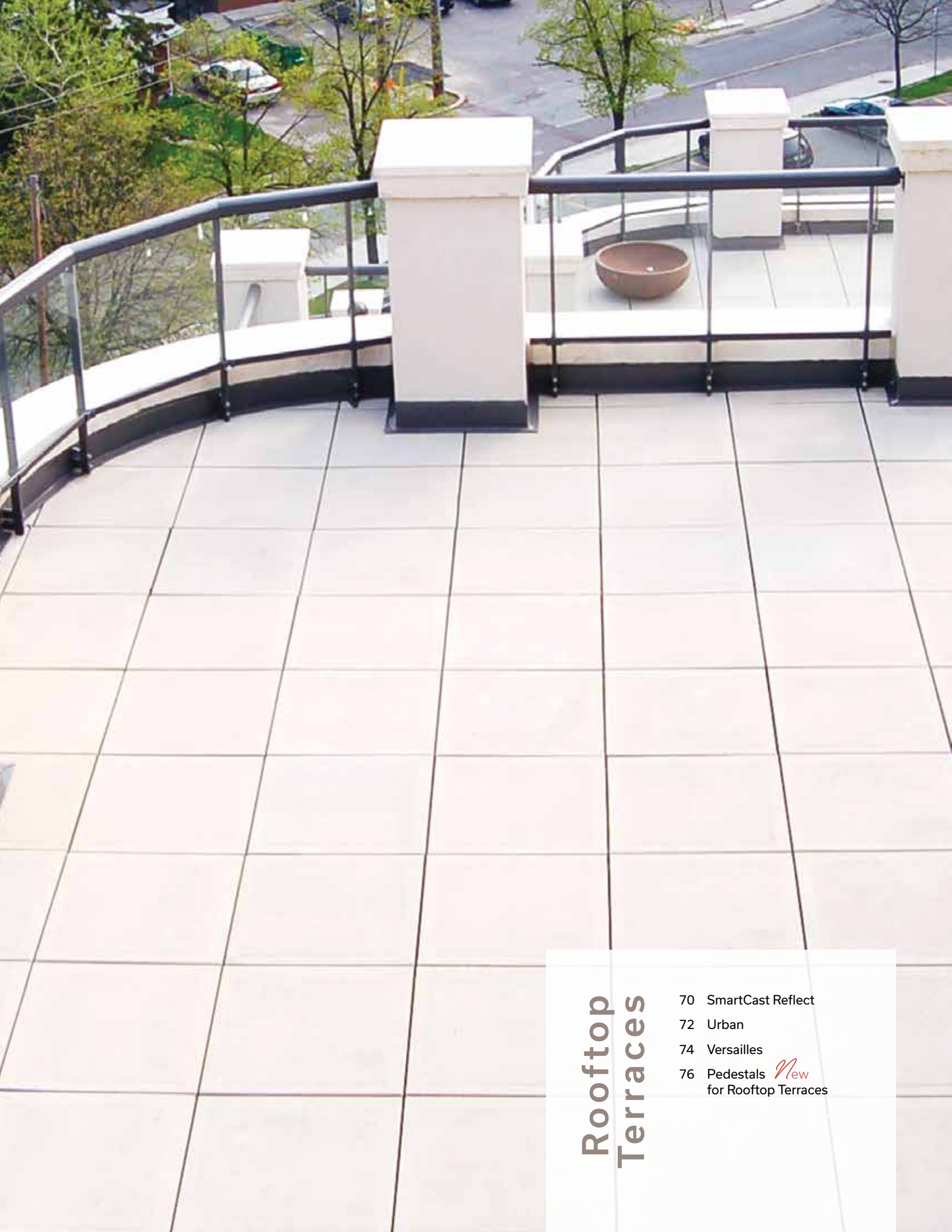

Rooftop Terraces

- 70 SmartCast Reflect
- 72 Urban
- 74 Versailles
- 76 Pedestals *New*
for Rooftop Terraces



SmartCast Reflect Slab

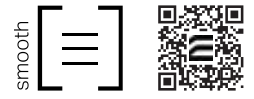

High solar reflectance paving for rooftop terraces

SmartCast Reflect slabs, due to their very high solar reflectance qualities, are the rooftop terrace paving material of choice when it comes to reducing the negative environmental impacts of heat islands.

The pristine white colour of SmartCast Reflect slabs achieves a laboratory-calculated solar reflectance index (SRI*) of 78. This slab is ideal for all rooftop terrace paving projects that aim to reduce ambient temperature (urban heat islands). It also complies with LEED requirements** for this purpose.

SmartCast Reflect slabs come in a 600 mm x 600 mm format with a thickness of 50 mm. They are highly durable and also have a slip-resistant surface to ensure pedestrian safety. The high quality concrete of the slab achieves a superior flexural strength exceeding 4.5 MPa. Slabs can be safely installed on pedestals and withstand live loads of 300 kg (660 lb).

SmartCast Reflect slabs have a slightly granular, slip-resistant finish with the look of cut stone.



Also available in a 40 mm thickness in the following colours:

Grey, Beige and Rockland Black



White

* SRI = Solar Reflectance Index. This is obtained by a test on the material to measure the ability of the surface to reflect sunlight. The lighter the material, the higher the reflectance. Lighter material better reflects sunlight and is therefore cooler. A surface covered with white slabs like SmartCast Reflect contributes significantly to reducing the ambient temperature.

** LEED (Leadership in Energy and Environmental Design) is a program that essentially aims to promote sound environmental practices and sustainable development in building construction or renovation. It is governed in the United States by the US Green Building Council (USGBC) and in Canada by the Canada Green Building Council (CaGBC).



Urban™ Slab

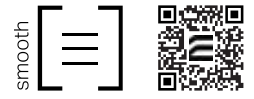

Thanks to its 55 mm height, Permacon's Urban™ slab is perfect for rooftops. Available in a variety of colours, the Urban slab matches Boulevard pavers, while its smooth texture gives a modern look to any of your projects.

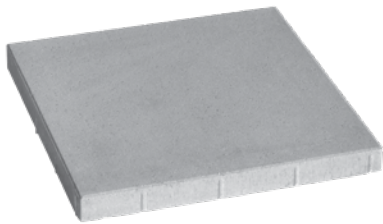

White



Beige **Grey**



Light Grey



Cinder Grey



Range **Bayona Grey**



THE UNIVERSITY OF THE STATE OF NEW YORK

Versailles Slab



Non-skid paving designed for rooftop terraces

Versailles slabs create a contemporary look in non-skid paving designed for prestigious rooftop terrace projects.

The anti-slip Versailles slab is designed for prestigious contemporary flat roof construction projects. Its optimal thickness of 50 mm minimizes the loads applied to buildings. It is specifically designed to be securely installed on pedestals.

Advantages

- Optimization of product dimensions enabling a reduction in loads transmitted to the building
- Non-skid, safe performance
- Can be used on granular base or pedestals



Alpine Grey



Trenton Grey





Pedestals for Rooftop Terraces *New*



Pedestals are ideal for raised patio installation on rooftop.



Permacon now offers a complete rooftop system. Our rooftop design service supports you in your projects. We now sell rooftop pedestals and our new software will determine pedestal and slab quantities for your project.





Alternative Landscaping

80 Artex Panel System



Artex Panel System

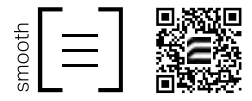

Artex lets you create a variety of landscaping elements, such as benches, flower planters, privacy screens, and fireplaces. Resistant and affordable, these modular panels perfectly complement other Permacon products.



Panel

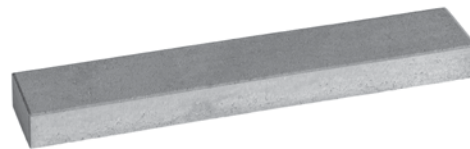

Capping



Range **Amber Beige**



Range **Scandina Grey**



Range **Shaded Grey**



Rockland Black



Resources and inspirations

Download our
Artex Idea Guide
for a wealth of
ideas.





Curbs

84 Street Curbs

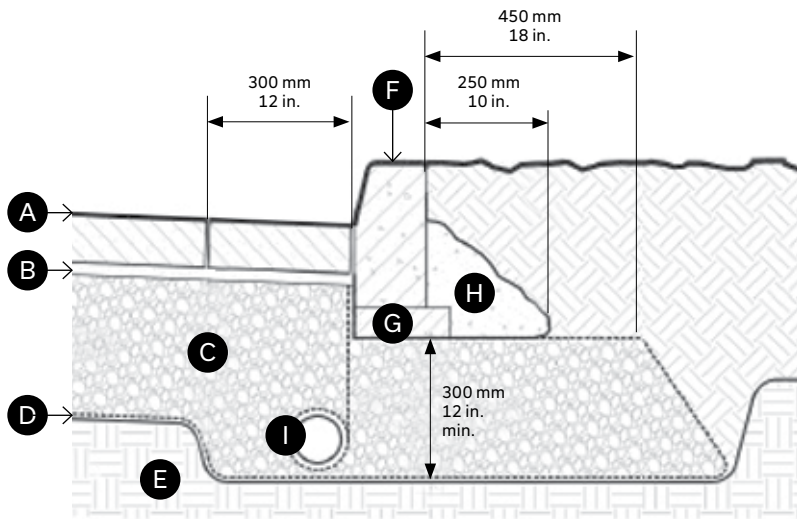

Precast concrete pavers and street curb roadway - heavy traffic

- Ⓐ Concrete pavers 100 mm
- Ⓑ Laying bed 25 mm
- Ⓒ Compacted granular foundation
- Ⓓ Geotextile
- Ⓔ Existing soil
- Ⓕ Precast concrete street curb
- Ⓖ Backup bricks
- Ⓗ Lean-mix concrete 15 MPa
- Ⓘ Precast drainage system
- ⓵ Planting area

Street Curbs

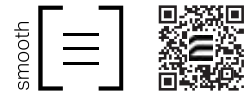

Versatility

Precast curbs can be used in the construction of roads, streets, parking lots, industrial yards, etc. The range of integrated components allows for a variety of design possibilities such as sidewalk curbs, driveway access ramps, 90 degree angles, as well as raised medians and planters.

Durability

Fabrication and controlled curing in the factory give the Permacon curbs high compressive strength, and make them highly resistant to freeze-thaw cycles, de-icing salts, and to impact and abrasion.

Economy

Street curbs prove to be the economical choice. Their life span is about twice that of poured concrete curbs. Their speed of installation allows work to be completed more rapidly. The modular components permit repairs or changes to be carried out quickly and economically.

Furthermore, the *Ministère des Transports du Québec* acknowledges the work done using precast street curbs like the ones made by Permacon has an added value is 40% greater than work done using poured-in-place curbs.

- Economically advantageous for small and medium-sized projects
- More durable than commercially available solutions with a compressive strength of 45 MPa

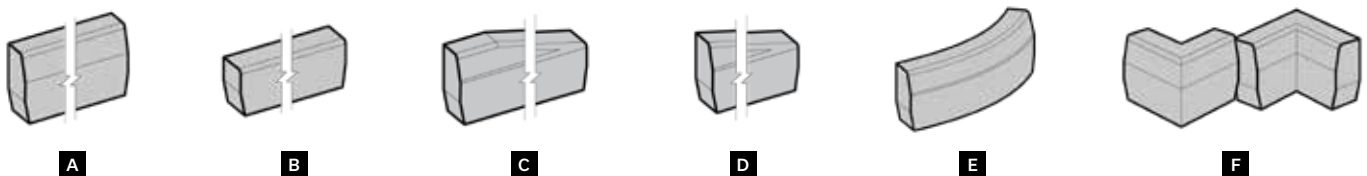

CURBS	DIMENSIONS
A High rised A1	300 x 150 x 1200 mm 12 x 6 x 48 in.
B Low rised B1	200 x 150 x 1200 mm 8 x 6 x 48 in.
C Transition 200 to 300 AB1 (left) BA1 (right)	200 to 300 x 150 x 1200 mm 8 to 12 x 6 x 48 in.
D Transition 175 to 300 AB1 (left) BA1 (right)	175 to 300 x 150 x 1200 mm 7 to 12 x 6 x 48 in.
E Outside curve C1 exposed	300 x 150 x 1200 mm 12 x 6 x 48 in.
F Corner inside/outside	300 x 150 x 300 mm 12 x 6 x 12 in.

Quantity of curved edges required for rotation angle of standardized curves						
Curve Angle	0.625	1.25	2.50	5.00	7.5	10.00
45°		1	2	4	6	8
90°	1	2	4	8	12	16
135°		3	6	12	18	24
180°	2	4	8	16	24	32
225°		5	10	20	30	40
270°	3	6	12	24	36	48
315°		7	14	28	42	56
360°	4	8	16	32	48	64

Techniseal® Polymeric Sands



SMART SAND® with NextGel TECHNOLOGY

- Designed for optimal jointing of interlocking pavers
- Ideal for narrow joints 1/16 in. - 1 in. wide
- For pedestrian and low-traffic areas such as driveways, walkways, patios, etc.

SmartSand is offered in **Tan**, **Urban Grey** or **Granite** by Permacon



Tan



Urban Grey



Ivory



Black



Granite



Dark Granite



Desert Tan



Iron Grey



HP NextGel

- Ideal for concrete, wet-cast, textured or clay pavers and porcelain tiles (only if mechanical compaction is possible)
- For false joints
- Ideal for joints 1/16 in. - 2 in. wide
- For high-humidity areas, heavy-sloped and high-traffic areas

HP NextGel is offered in **Tan**, **Urban Grey**, **Ivory**, **Black** or **Granite** by Permacon



NOCO NO COMPACTION

- Ideal for flagstone, concrete and wet-cast pavers such as imitation of CobbleStone, highly textured surfaces, large slabs and porcelain tiles (when joints are 1/4 in. or larger)
- For false joints
- Ideal for wide joints from 1/4 to 2 in. with intersecting spaces up to 4 in.
- The true alternative to mortar, stone dust and polymeric stone dust

Noco is offered in **Desert Tan** or **Iron Grey** by Permacon



LEED and Permacon

Permacon has been a leader in the landscaping and masonry fields for over 70 years. We have developed a wide array of products that have fully satisfied our customers through the years. Our world has changed and will continue to evolve over time. For this reason, we need to see as far into the future as possible, particularly in the environmental field.

Our planet needs to be looked after in a responsible manner. We need to efficiently use our resources and think how we may reuse what we extract so that they get employed at its best. Permacon offers several products that are made to comply with the LEED specifications and criteria.

LEED (Leadership in Energy and Environmental Design) promotes environmental sustainability and focuses on the following main areas:

- Sustainable sites
- Water efficiency
- Energy and Atmosphere
- Materials and Resources
- Innovation in Design Process
- Indoor Environmental Quality

Clearly, Permacon is an environmentally responsible company. We manufacture products that look further into the future, always keeping in mind the sustainability of the product and its environmental efficiency while preserving our planet and our home.

Our products contribute to the indoor environmental quality by decreasing the amount of indoor pollutants that may be irritant, harmful and/or odorous to the occupants and installers.

We have also taken the necessary measures to consume gas in a more efficient manner by decreasing its use over the years and using this natural resource in a more efficient way. We also contribute through our packaging by reusing our wooden pallets and plastic.

The following chart displays the main LEED areas and how we can contribute to this sustainability effort.

Leed and Permacon - cont'd

General LEED Specifications Chart

Category	Description	Industry	Permacon*
Sustainable sites	Credit 6.1 Stormwater Design: Quantity control (1 point)	Limit disruption of natural hydrology by reducing impervious cover, increasing on-site infiltration and managing storm water runoff.	Permacon offers pavers that meet this requirement. Our permeable Boulevard Drain paver has as an infiltration rate of 685 in/hr. Another product is Turfstone that has a runoff coefficient of 0.628, therefore allowing a high permeable rate.
	Credit 7.1 Heat Island Effect: Non-Roof (1 point)	Reduce heat islands (thermal gradient differences between developed and undeveloped areas) to minimize impact on microclimate and human and wildlife habitat.	This applies to all of our pavers and slabs product lines that are light coloured and have a high solar reflectance content in the product mix.
Materials and Resources	Credit 2.1 Construction Waste Management: Divert 50% from disposal (1 point)	Divert construction and demolition debris from disposal in landfills and incinerators. Redirect recyclable recovered resources back to the manufacturing process. Redirect reusable materials to appropriate sites.	Permacon offers modular pavers in various styles and dimensions that offer less cutting on site.
	Credit 2.2 Construction Waste Management: Divert 75% from disposal (2 points)		
	Credit 3.1 Materials Reuse: 5% (1 point) Credit 3.2 Materials Reuse: 10 % (2 points)	Reuse building materials and products in order to reduce demand for raw materials and to reduce waste. This further reduces the impact associated with the extraction and processing of virgin resources.	All of our masonry and landscaping products may be reused on site at any time during the life of the product. Also, all of our products have a long life span.
Indoor Environmental Quality	Credit 5.1 Regional Materials 20 % extracted and manufactured regionally (1 point)	Increase demand for building materials and products that are extracted, processed and manufactured within the region. This supports the regional economy and reduces the environmental impact resulting from transportation.	All our natural resources are taken from areas near our manufacturing sites. The majority of them come from no far than 800 km away from its place of fabrication. This also means that there is less transportation involved in the manufacturing process, therefore less pollution.
	Credit 5.2 Regional Materials 30 % extracted and manufactured regionally (2 points)		
Indoor Environmental Quality	Credit 4.2 Low-emitting materials: Paints and coatings (1 point)	Decrease the amount of indoor air contaminants that may be irritant, harmful and/or odorous to the occupants and installers.	Since our masonry product line offers a natural and attractive finish, there is no need to paint the product while contributing to the quality of the air.

Solar Reflective Index - Architectural

Solar Reflective Index (SRI) is simply a mathematical formula, using the two experimentally derived coefficients, solar reflectance and thermal emittance, to generate a single number. Solar Reflectance is a percentage of sunlight that is reflected by a surface when it is "hit" by sunlight. A value of 0 indicates that the material absorbs all solar energy and a value of 1.0 indicates total reflectance. Aged solar reflectance is the solar reflectance of the surface after three years, which, typically is lower than the initial reflectance value. According to LEED® v4, Aged SRI and SR are optional requirements. This report has no three-year aged value, use materials that meet the initial SR and SRI requirements.

LEED® v4	Initial SRI	3 year aged SRI	Initial Solar Reflectance	3-year aged Solar Reflectance
Non-Roof Applications	-	-	0.33	0.28
Roof Top Application (if Low Sloped Roof ≤ 2:12)	82	64	-	-
Parking Under Cover	39	32	-	-

Product	Colour	Smooth		Granitech	
		Solar Reflectance Index (SRI)	Solar Reflectance (SR)	Solar Reflectance Index (SRI)	Solar Reflectance (SR)
AGORA Paver	Range Amber Beige	37	0.37	-	-
	Range Shaded Grey	20	0.22	-	-
	Range Scandinia Grey	32	0.32	-	-
	Rockland Black	N/A	N/A	-	-
BOULEVARD Paver	Light Cinder Grey	-	-	28	0.28
	Cinder Grey	21	0.23	34	0.32
	Light Charcoal	16	0.19	24	0.24
	Charcoal	22	0.23	19	0.21
	Black ETX	5	0.10	-	-
	Red	26	0.26	19	0.21
	Light Grey	43	0.39	65	0.56
	Beige Grey	39	0.37	47	0.42
	Beige	41	0.38	41	0.37
	White	67	0.57	69	0.59
	Brown	21	0.22	N/A	N/A
	Yellow	37	0.35	36	0.35
	Terracotta	25	0.26	29	0.29
	Caledonia	N/A	N/A	29	0.29
	Opal White	-	-	49	0.45
	Stanstead Grey	-	-	40	0.37
	Shefford Beige	-	-	39	0.37
	Cambrian Brown	-	-	13	0.16
	Cambrian Black	-	-	11	0.15
	URBAN Slab	White	67	0.57	-
Beige Grey		39	0.37	-	-
Cinder Grey		21	0.23	-	-
Light Grey		43	0.39	-	-
Range Bayona Grey		11	0.14	-	-
PALEO-TEC Paver	Light Grey	43	0.39	-	-
	Norvick Grey	22	0.22	-	-
	Rockland Black	11	0.15	-	-
	Range Brownstone Red	14	0.17	-	-
SMARTCAST REFLECT Slab	White	78	0.66	-	-
VERSAILLES Paver	Alpine Grey	-	-	31	0.33
	Trenton Grey	-	-	21	0.25
VERTEX Paver	White	67	0.57	-	-
	Cinder Grey	21	0.23	-	-
	Light Charcoal	16	0.19	-	-
	Charcoal	22	0.23	-	-
	Black ETX	5	0.10	-	-
	Light Grey	43	0.39	-	-
	Beige Grey	39	0.37	-	-
NOON Porcelain Tile	Daylight	62	0.53	-	-
	Ember	33	0.31	-	-
	Glacier	63	0.54	-	-
QUARZITI 2.0 Porcelain Tile	Mantle	20	0.21	-	-
	Waterfall	39	0.36	-	-



- : Not producing this item

N/A : Value not available

The SR and SRI values above are from independent laboratories.

Applications: ROADWAY Architectural Pavers

Pavers specially developed for vehicular applications on streets with heavy traffic.

 Heavy Commercial  Vehicular



Ports and industrial areas



Roads



Roundabouts



Pedestrian crosswalks



Bus stops



Loading docks



Boulevard TLI 100 150 x 300

100 x 150 x 300 mm 4 x 5 7/8 x 11 13/16 in.



Boulevard TLI 100 300 x 300

100 x 300 x 300 mm 4 x 11 13/16 x 11 13/16 in.



Boulevard TLI 100 300 x 700

100 x 300 x 700 mm 4 x 11 13/16 x 27 9/16 in.

Can be installed with **Boulevard TLI 100 - 150 x 300, 300 x 300**



Boulevard TLI 100 Crescendo

100 x 300 x 400 mm 4 x 11 13/16 x 15 3/4 in. A

100 x 300 x 500 mm 4 x 11 13/16 x 19 11/16 in. B

100 x 300 x 600 mm 4 x 11 13/16 x 23 5/8 in. C

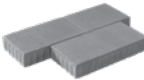

Boulevard TLI 150 200 x 200

150 x 200 x 200 mm 5 7/8 x 7 7/8 x 7 7/8 in.

Can be installed with **Boulevard TLI 150 - Crescendo 320**
Can also be installed in light commercial applications



Boulevard TLI 150 125 x 500

150 x 500 x 125 mm 5 7/8 x 19 11/16 x 4 15/16 in.

Can be installed with **Boulevard TLI 150 - 250 x 500, 500 x 500, 500 x 750** and **Crescendo 125**



Boulevard TLI 150 250 x 500

150 x 500 x 250 mm 5 7/8 x 19 11/16 x 9 7/8 in.

Can be installed with **Boulevard TLI 150 - 125 x 500, 500 x 500, 500 x 750** and **Crescendo 125**



Boulevard TLI 150 500 x 500

150 x 500 x 500 mm 5 7/8 x 19 11/16 x 19 11/16 in.



Boulevard TLI 150 750 x 500

150 x 750 x 500 mm 5 7/8 x 29 1/2 x 19 11/16 in.

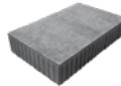

Boulevard TLI 150 Crescendo 125

150 x 125 x 333.33 mm 5 7/8 x 4 15/16 x 13 1/8 in. A

150 x 125 x 416.67 mm 5 7/8 x 4 15/16 x 16 3/8 in. B

150 x 125 x 458.33 mm 5 7/8 x 4 15/16 x 18 in. C

150 x 125 x 500 mm 5 7/8 x 4 15/16 x 19 11/16 in. D

150 x 125 x 541.67 mm 5 7/8 x 4 15/16 x 21 5/16 in. E

150 x 125 x 583.33 mm 5 7/8 x 4 15/16 x 23 in. F

Can be installed with **Boulevard TLI 150 - 125 x 500, 250 x 500, 500 x 500, 500 x 750**



Boulevard TLI 150 Crescendo 320

150 x 320 x 240 mm 5 7/8 x 12 5/8 x 9 1/2 in. A

150 x 320 x 320 mm 5 7/8 x 12 5/8 x 12 5/8 in. B

150 x 320 x 360 mm 5 7/8 x 12 5/8 x 14 3/16 in. C

150 x 320 x 400 mm 5 7/8 x 12 5/8 x 15 3/4 in. D

150 x 320 x 440 mm 5 7/8 x 12 5/8 x 17 5/16 in. E

Can be installed with **Boulevard TLI 150 - 200 x 200**
Can also be installed in light commercial applications

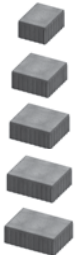

Boulevard TLI 200 Crescendo 300

200 x 300 x 300 mm 7 7/8 x 11 13/16 x 11 13/16 in. A

200 x 300 x 412,5 mm 7 7/8 x 11 13/16 x 16 1/4 in. B

200 x 300 x 487,5 mm 7 7/8 x 11 13/16 x 19 3/16 in. C

200 x 300 x 525 mm 7 7/8 x 11 13/16 x 20 5/8 in. D

200 x 300 x 562,5 mm 7 7/8 x 11 13/16 x 22 1/8 in. E

200 x 300 x 637,5 mm 7 7/8 x 11 13/16 x 25 1/8 in. F

200 x 300 x 675 mm 7 7/8 x 11 13/16 x 26 9/16 in. G

Can be installed with **Boulevard TLI 150 - 200 x 200**
Can also be installed in light commercial applications

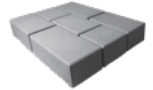

Boulevard 300 150 x 300

100 x 150 x 300 mm 4 x 5 7/8 x 11 13/16 in.

Can be installed with **Boulevard 300 - 150 x 450, 100 x 450, 200 x 600, 600 x 600, 300 x 600**

Can also be installed in light commercial applications



Boulevard 300 300 x 300

100 x 300 x 300 mm 4 x 11 13/16 x 11 13/16 in.

Can be installed with **Boulevard 300 - 150 x 450, 100 x 450, 200 x 600, 600 x 600, 300 x 600**

Can also be installed in light commercial applications



Paleo-Tec

100 x 140 x 220 mm 4 x 5 1/2 x 8 5/8 in.



All Boulevard Crescendo Pavers can be installed together.

Applications: Architectural Pavers

Pavers used for vehicular and pedestrian applications.

 Light Commercial  Pedestrian  Vehicular



Parking lots



Medians



Street sidewalks



Commercial spaces



Parks



Walkways



Boulevard Hexagon

90 x 150 x 300 - 254 mm 3 1/8 x 5 7/8 x 11 11/16 - 10 1/16 in.



Boulevard Tactile

100 x 300 x 300 mm 4 x 11 13/16 x 11 13/16 in.



Boulevard TLI 80 120 x 240

90 x 120 x 240 mm 3 1/8 x 4 3/4 x 9 1/2 in.



Boulevard TLI 90 160 x 240

90 x 160 x 240 mm 3 1/2 x 6 5/16 x 9 1/2 in.



Can be installed with **Boulevard TLI 90 Grand Rectangle** and **Crescendo 320**

Boulevard TLI 90 320 x 520

90 x 320 x 520 mm 3 1/2 x 12 5/8 x 20 23/48 in.

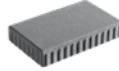

Can be installed with **Boulevard TLI 90 Small Rectangle** and **Crescendo 320**

Boulevard TLI 90 Crescendo 320

90 x 320 x 240 mm 3 1/2 x 12 5/8 x 9 1/2 in. A

90 x 320 x 320 mm 3 1/2 x 12 5/8 x 12 5/8 in. B

90 x 320 x 360 mm 3 1/2 x 12 5/8 x 14 3/16 in. C

90 x 320 x 400 mm 3 1/2 x 12 5/8 x 15 3/4 in. D

90 x 320 x 440 mm 3 1/2 x 12 5/8 x 17 5/16 in. E



Can be installed with **Boulevard TLI 90 Small** and **Large Rectangle**

Boulevard 300 100 x 450

100 x 100 x 450 mm 4 x 4 x 17 3/4 in.



Can be installed with **Boulevard 300 - 150 x 300, 300 x 300**

Boulevard 300 150 x 450

100 x 150 x 450 mm 4 x 5 7/8 x 17 3/4 in.

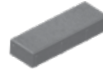

Can be installed with **Boulevard 300 - 150 x 300, 300 x 300**

Boulevard 300 100 x 600

100 x 100 x 600 mm 4 x 4 x 23 5/8 in.

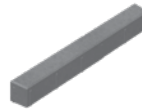

Can be installed with **Boulevard 300 - 150 x 300, 300 x 300**

Boulevard 300 200 x 400

100 x 200 x 400 mm 4 x 7 7/8 x 15 3/4 in.



Can be installed with **Boulevard 300 - 150 x 300, 300 x 300**

Boulevard 300 200 x 600

100 x 200 x 600 mm 4 x 7 7/8 x 23 5/8 in.



Can be installed with **Boulevard 300 - 150 x 300, 300 x 300**

Boulevard 300 300 x 600

100 x 300 x 600 mm 4 x 11 13/16 x 23 5/8 in.



Can be installed with **Boulevard 300 - 150 x 300, 300 x 300**

Boulevard 300 600 x 600

100 x 600 x 600 mm 4 x 23 5/8 x 23 5/8 in.



Can be installed with **Boulevard 300 - 150 x 300, 300 x 300**

Boulevard 500 500 x 500

100 x 500 x 500 mm 4 x 19 11/16 x 19 11/16 in.



Available in several finishes

Can also be installed in light commercial applications

Agora

80 x 167 x 300 mm 3 1/8 x 6 9/16 x 11 in. A

80 x 200 x 300 mm 3 1/8 x 7 7/8 x 11 in. B

80 x 233 x 300 mm 3 1/8 x 9 3/16 x 11 in. C

Agora A, B, C are sold together



Agora Large Rectangle

80 x 233 x 300 mm 3 1/8 x 9 3/16 x 11 in.



Agora 100

100 x 167 x 300 mm 4 x 6 9/16 x 11 in. A

100 x 200 x 300 mm 4 x 7 7/8 x 11 in. B

100 x 233 x 300 mm 4 x 9 3/16 x 11 in. C

Agora A, B, C are sold together

Can also be installed in light commercial applications



Agora 100 - Large Rectangle

100 x 233 x 300 mm 4 x 9 3/16 x 11 in.



Vertex

100 x 150 and 300 x 600 mm 4 x 5 7/8 and 11 13/16 x 23 5/8 in.

Can be installed with **Boulevard 300**

A and B



Applications: ECOLOGICAL Architectural Pavers



Environmentally friendly pavers used for vehicular and pedestrian applications.

Light Commercial
 Pedestrian
 Vehicular
 Permeable



Parking lots



Sidewalks



Parks

Boulevard Verde

100 x 300 x 450 mm	4 x 11 13/16 x 17 3/4 in.
--------------------	---------------------------



Boulevard Drain

100 x 209 x 209 mm	4 x 8 1/4 x 8 1/4 in.
100 x 150 x 300 mm	4 x 5 7/8 x 11 13/16 in.



Agora Aqua

80 x 167 x 300 mm	3 1/8 x 6 9/16 x 11 in.	A
80 x 200 x 300 mm	3 1/8 x 7 7/8 x 11 in.	B
80 x 233 x 300 mm	3 1/8 x 9 3/16 x 11 in.	C
80 x 233 x 300 mm	3 1/8 x 9 3/16 x 11 in.	Large Rectangle

Agora A, B, C are sold together

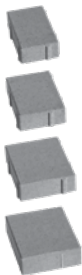

AquaPave

80 x 98 x 198 mm	3 1/8 x 3 41/48 x 7 in.
------------------	-------------------------



Turfstone Paver

100 x 598 x 398 mm	4 x 23 9/16 x 15 5/8 in.
--------------------	--------------------------



Virage

80 x 300 x 300 mm	3 1/8 x 11 7/8 x 11 7/8 in.
-------------------	-----------------------------





Zen

80 x 190 x 380 mm	3 1/8 x 7 1/2 x 15 in.
-------------------	------------------------



Applications: ROOFTOP Architectural Slabs

Slabs used for rooftop terraces.

 Pedestrian  Rooftop

Granular Base

Pedestal Rooftop

High Reflectance

SmartCast Reflect

50 x 600 x 600 mm	2 x 23 5/8 x 23 5/8 in.			
-------------------	-------------------------	---	--	---



Urban

55 x 610 x 610 mm	2 x 24 x 24 in.			
-------------------	-----------------	---	--	---



Versailles

50 x 610 x 610 mm	2 x 24 x 24 in.			
-------------------	-----------------	---	--	---



Applications: Retaining WALL Systems

Retaining walls (maximum allowable above ground height).

		GRAVITY WALLS				REINFORCED WALLS			
		WITH surcharge				WITH surcharge			
		WITHOUT surcharge	Slope 1V: 3H	Parking 5 kN/m ² (100 lb/ft ²)	Roads 12 kN/m ² (250 lb/ft ²)	WITHOUT surcharge	Slope 1V: 3H	Parking 5 kN/m ² (100 lb/ft ²)	Roads 12 kN/m ² (250 lb/ft ²)
	Slope								
Grande	0 degrees	7.55 ft. (2.3 m)	5.25 ft. (1.6 m)	6.56 ft. (2.0 m)	4.59 ft. (1.4 m)	30.00 ft. (9.0 m)	30.00 ft. (9.0 m)	30.00 ft. (9.0 m)	30.00 ft. (9.0 m)
	9 degrees	9.51 ft. (2.9 m)	6.56 ft. (2.0 m)	8.53 ft. (2.6 m)	6.56 ft. (2.0 m)	30.00 ft. (9.0 m)	30.00 ft. (9.0 m)	30.00 ft. (9.0 m)	30.00 ft. (9.0 m)
	17 degrees	11.81 ft. (3.6 m)	8.36 ft. (2.7 m)	10.50 ft. (3.2 m)	8.53 ft. (2.6 m)	30.00 ft. (9.0 m)	30.00 ft. (9.0 m)	30.00 ft. (9.0 m)	30.00 ft. (9.0 m)
Keystone	2 degrees	1.67 ft. (0.5 m)	N/A	N/A	N/A	30.00 ft. (9.0 m)	30.00 ft. (9.0 m)	30.00 ft. (9.0 m)	30.00 ft. (9.0 m)
	9 degrees	2.33 ft. (0.7 m)	N/A	N/A	N/A	30.00 ft. (9.0 m)	30.00 ft. (9.0 m)	30.00 ft. (9.0 m)	30.00 ft. (9.0 m)

Please note that with proper engineering the above wall heights can be exceeded. For more information about Grande and Keystone wall designs, please contact your Permacon representative.

Applications: Artex Panel System

Artex lets you create a variety of landscaping elements.



Bench and Planter



Corner Bench and Planter



Bench and Vertical Planter



Small BBQ



Recessed Wood Fire Pit



Recessed Gas Fire Pit



Gas Fire Pit



Recessed Rectangular Gas Fire Pit



Rectangular Gas Fire Pit



High Top Gas Firepit



Square Planter



Rectangular Planter



Raised Garden



Corner Multilevel Raised Garden



Multilevel Raised Garden

Artex Panel System

76 x 457 x 914 mm	3 x 18 x 36 in.	18 x 36 panel
76 x 152 x 914 mm	3 x 6 x 36 in.	6 x 36 capping





Medium BBQ



Long BBQ



L-shape BBQ



Corner BBQ and Pizza Grill



BBQ with Luxury Counter and Bar



Counter and Bar

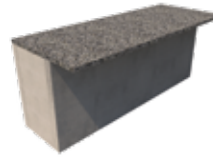

Large Counter



Large Counter and Bar



Vertical Planter



Privacy Wall with Bench



Privacy Wall with Planter



Privacy Wall with Vertical Planter



L-shape Bench with Vertical Planter



BBQ with Bench with Vertical Planter



Fireplace with Bench and Wood Pergola

Warranty

Institutional, Commercial and Industrial Landscaping

Permacon's warranty applies to landscaping and masonry products including Suretouch intended for institutional, commercial and industrial use¹. This warranty statement affirms that products manufactured by Permacon meet the requirements of the Canadian Standard Association (CSA) and American Society for Testing and Materials (ASTM).

Permacon guarantees that, as of the date of delivery, our concrete products are free from manufacturing defects. Provided the conditions set forth below are met, Permacon guarantees the structural integrity of the concrete in its landscaping products for a period of 5 years from the date of purchase of the product. The masonry products will be guaranteed for a period of 50 years. The warranty applies to normal, non-abusive use of the product.

IN ALL CASES DETAILED BELOW, THE WARRANTY IS LIMITED TO THE PRODUCTS' MARKET VALUE.

How do I make a claim?



permacon.ca/en/warranty/



Proof of purchase will be required to proceed with a claim request. No claims will be accepted without proof of purchase.²

All claims must be reported within 15 days of the discovery of a product's defect. To validate a claim, a Permacon representative will arrive to inspect the defective products in order to confirm whether the claim is admissible. Therefore, it is essential to provide Permacon with the necessary access to inspect and take photos of the products in question.

This warranty is the only one that is presently offered. Because Permacon continually improves and modifies its products, it may alter and discontinue products at any time, and therefore may replace warranty-covered products with products of similar quality or offer monetary compensation if the products under warranty have been discontinued or are no longer on the market while the warranty is active.

In the event that a product is found to be non-conforming by Permacon or an authorized representative of the company, and in order to proceed with compensation, Permacon will take into account the number of months during which the

landscaping or masonry products were in the possession of the owner or their contractor, up to the date of the claim, and will prorate the amount of the payment or replacement to be made accordingly.

For example: if the purchaser makes a warranty claim in the last month of the 2nd year of the warranty (i.e., the 24th month), the manufacturer, at its sole discretion, shall either :

- Provide a replacement for the product in question if still available (only the defective product will be replaced);
- Return 36/60 of the price paid for the products to the owner. No labor, transportation, or other compensation costs will be covered by Permacon.

Transferability

The warranty is transferable. Proof of warranty registration will still be required in the event of a claim. The prorated period will be based on the warranty period remaining as an assignee, if the purchaser transfers the limited warranty to a subsequent owner, as described above.

¹ The following areas are defined as institutional, commercial and industrial: public areas, businesses, family dwelling of six units or more, and all other non-residential areas

² The following documents are considered valid proof of purchase: an invoice from an authorized Permacon distributor or an invoice from a landscape contractor, general contractor, or mason

Exclusions

A landscaping or masonry product installed on an area of more than **100 square feet** confirms the acceptance of the product received on site and that no claim can be made to Permacon regarding the colour, size, or texture of the product.

This limited warranty excludes all products not supplied by Permacon, as well as any defects, failures, or damages that may result from the actions listed below:

- Contact with chemicals or cleaning products;
- Damage caused by pressure washers;
- Improper installation or other construction activities that do not comply with the installation standards established by ICPI, NCMA or IMQ, the National Building Code or the installation methods and tips recommended by Permacon. The installation guides provided by Permacon represent certain installation situations and are not exhaustive. It is therefore strongly recommended that you consult a qualified professional to ensure the proper installation of Permacon products on a specific job site;
- Defective design or construction resulting in sagging, shifting, or failure;
- Breakage due to shock, impact, or excessive load during handling, use, or transportation;
- Natural disaster or other uncontrollable event;
- Breakage and damage to products caused by soil movement or building movement as well as misuse of construction, compaction, or snow removal equipment. The warranty does not cover surface deterioration caused by the misuse of sodium chloride (NaCl) to de-ice pavers, slabs, or steps;
- The use of sodium chloride (NaCl) on the following products:
 - Step Valentia;
 - Valentia Block;
- Be.OnStone, Mirage and Techniseal products sold by Permacon.

Installation

When installing masonry products, it is vital that the work be cleaned to remove residue and contaminants left on the stone or brick. Permacon accepts no responsibility for stains and colour changes caused by installation residue or the consequences of cleaning said residue.

Colour

The presence of natural ingredients used in the manufacturing process varies from one product to another. Therefore, the product received on the job site will not be completely identical to the products presented in our commercial presentations (catalogs, samples, displays). Any difference in colour cannot be attributed to the guarantee.

Photos of our products in landscape and masonry brochures, as well as in displays such as masonry panels and landscape racks at our distributors, are not an exact representation of the products that will be delivered to the job site. Permacon offers a variety of products with different colours to reproduce the appearance of natural stone. It is therefore strongly recommended that you view several products directly from your authorized Permacon distributor to see all available colours.

It is the purchaser's responsibility to approve the products delivered to the job site prior to installation and to ensure that the colour is satisfactory. It is also recommended to mix products from different pallets received on site. Since variations in colour shades are a natural phenomenon, Permacon does not guarantee colour uniformity between different pallets on the same job site. Product installation constitutes acceptance.

Polymeric film

A whitish polymeric film can be found on the surface of our products. This is the result of an inadequate use of polymeric sand. Improper cleaning of slabs and pavers prior to the application of water on the products' surface can cause this whitish polymeric film. This film does not affect the structural integrity of the product. Permacon cannot be held responsible for this phenomenon, which is not covered by the warranty.

Efflorescence

White traces on the surface of the product are caused by a natural phenomenon called efflorescence. More visible on darker products, efflorescence affects neither the intrinsic technical qualities nor the structural integrity of our products. The possible appearance of efflorescence cannot be the subject of any guarantee on our part. In most cases, efflorescence disappears by itself over time.

Our Preventive Maintenance Guide for Concrete Landscaping Products is available on our web site permacon.ca

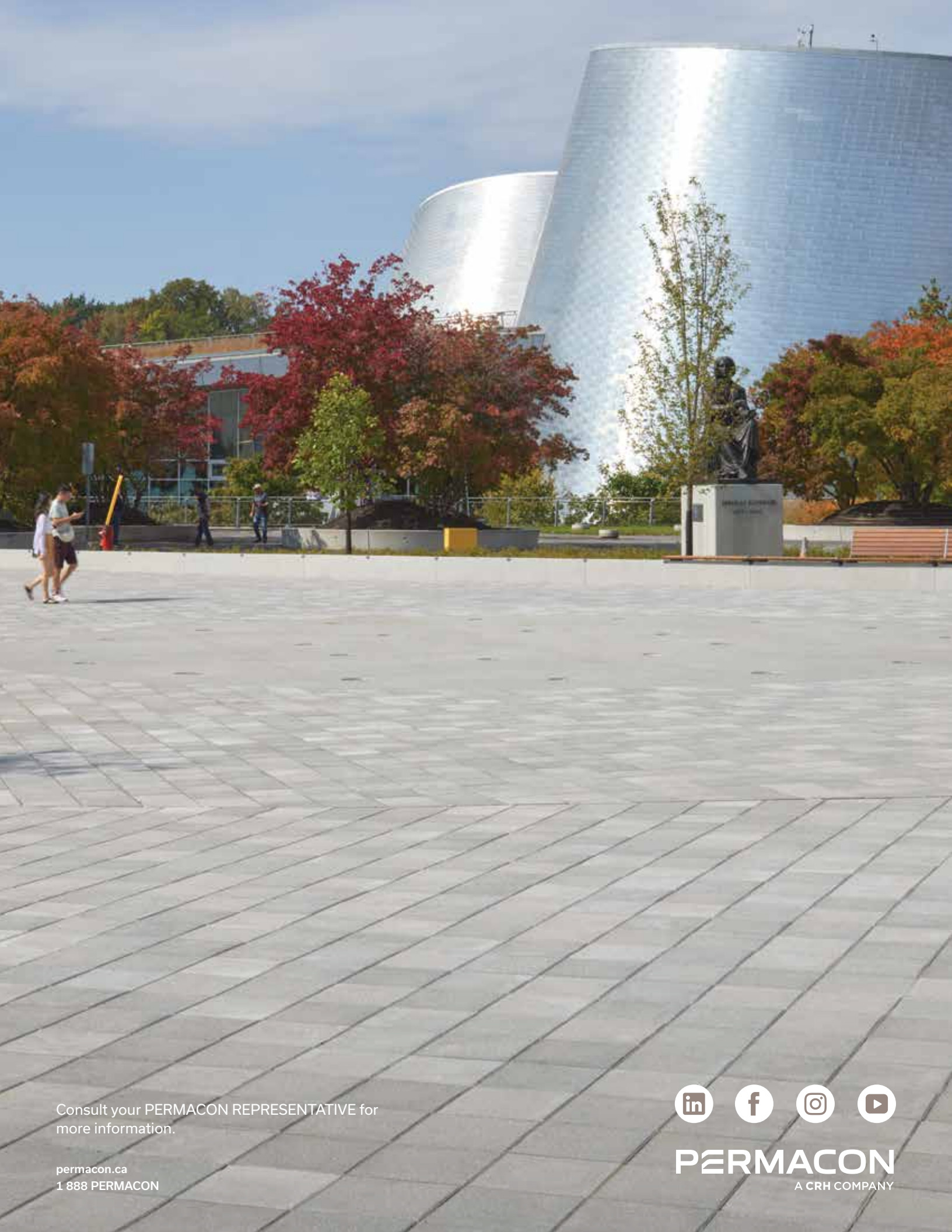

Consult your PERMACON REPRESENTATIVE for more information.

permacon.ca
1 888 PERMACON



PERMACON
A CRH COMPANY